



**READ THROUGH THIS MANUAL
BEFORE STARTING CONSTRUCTION.
IT CONTAINS IMPORTANT INSTRUCTIONS
AND WARNINGS CONCERNING THE
ASSEMBLY AND USE OF THIS MODEL.**



SPECIFICATION

- Wingspan: 1800mm (70.9 in)
- Length: 1467mm (57.7 in)
- Flying weight: 6000-6200 g
- Wing area: 56.3 dm²
- Wing loading: 105g/dm²
- Wing type: Naca airfoils
- Gear type: Electric Retract Gear Rotary 90 degree With CNC Suspension Metal Struts For Main Gear (Included)
- Spinner size: 25mm (not included)
- Radio: 8 channel radio system minimum. 8 standard hi-torque servo: 2 aileron; 2 flap; 2 elevator; 1 rudder; 1 throttle; (not included)
- Engine: .120 two stroke or .140 four stroke (plug engine) OR 20-22 cc (gas engine) (not included)
- Recommended receiver battery: 6.0V 2400/2600mAh NiMH (not included)
- Propeller: suit with your engine
- Gravity CG: 115 mm (4.5 in) Back from the leading edge of the wing, at the fuselage

- Control throw Ailerons: Low: 12mm up/down; High: 15mm up/down
 - Control throw Elevators: Low: 12mm up/down; High: 15mm up/down
 - Control throw Flaps: Mid: 15mm down; Landing: 25mm down
 - Control throw Rudder: Low: 20mm right/left; High: 30mm right/left
 - Experience level: Intermediate
 - Plane type: scale military
- RECOMMENDED MOTOR AND BATTERY SET UP**
- Brushless Motor outrunner: 2300/2500W- 450KV (rpm/volt) (not included)
 - Lipo cell: 6 cells / 5500 – 6000mAh (not included)
 - Esc: HV 80-100A (not included)



UNDER SAFETY PRECAUTIONS

This radio control model is not a toy!

- It is highly recommended that first-time builders seek advice of experienced modelers before beginning assembly.
- Assemble this kit only in places out of children's reach!
- Take enough safety precautions prior to operating this model.
You are responsible for this model's assembly and safe operation!
- Always keep this instruction manual ready at hand for quick reference, even after completing the assembly.

TABLE OF CONTENTS

| | | | |
|--|----|--|----|
| Introduction | 1 | Installing the engine | 24 |
| Warranty | 2 | Installing the engine mount | 25 |
| Disclaimer | 2 | Installing the fuel tank | 26 |
| Safety precaution | 2 | Installing the throttle pushrod servo | 29 |
| Important building notes | 2 | Installing the engine | 29 |
| Suggestion | 2 | Installing the throttle | 32 |
| Flight warnings | 2 | Mounting the cowl | 34 |
| Flight warnings | 3 | Installing the propeller | 36 |
| Covering tools | 3 | Installing the receiver and battery | 36 |
| Adhesives and required tools | 3 | Installing the switch | 36 |
| Academy of model aeronautics national | | Installing the electric motor (ep version) | 37 |
| model aircraft safety code | 3 | Balancing | 39 |
| Important notes | 5 | Lateral balance | 41 |
| Preparations | 5 | Control throws | 41 |
| Installing the ailerons and flaps | 5 | Flight preparation pre flight check | 42 |
| Installing the ailerons and flaps servos | 7 | For your radio installation | |
| Installing the ailerons and flaps linkages | 8 | Basic connection for airplane | |
| Installing the plastic cover | 10 | And adjustment of servos | 42 |
| Installing the gun | 11 | Main gear dimensional detail | 43 |
| Installing the main landing gear | 12 | Tail gear dimensional detail | 43 |
| Electric retract system | 15 | Decoration | 44 |
| Secure the wing to the fuselage | 16 | Exploded view | 45 |
| Horizontal stabilizer installation | 16 | Exploded view | 46 |
| Installing rudder and tail gear | 18 | | |
| Installing the rudder pushrod | 20 | | |
| Installing the elevator pushrod | 22 | | |

INTRODUCTION

Thank you for purchasing Phoenix Model products. With over 20 years experience in production and fly testing, Phoenix Model is committed to bring the best quality products and good service to customers. Along with a team of creative engineers and skilled workers, we will always accompany with customers by our great experiences, fully enthusiasm... which will burn our passion!! Joining with us to explore and conquer challenges in the sky ...

Your satisfaction is our success. Please read through this manual before starting construction.

Academy of Model Aeronautics: If you are not already a member of the AMA, please join! The AMA is the governing body of model aviation and membership provides liability insurance coverage, protects modelers' rights and interests and is required to fly at most R/C sites.

Academy of Model Aeronautics

5151 East Memorial Drive Muncie, IN 47302-9252

Tele. (800) 435-9262

Fax (765) 741-0057

Or via the Internet at: <http://www.modelaircraft.org>



WARRANTY

Phoenix Model guarantees the component parts in this kit to be free from defects in both material and workmanship at the date of purchase by the purchaser.

This warranty does not cover cosmetic damage or damage due to acts of God, accident, misuse, abuse, negligence, commercial use, or modification of or to any part of the Product.

This warranty does not cover damage due to improper installation, operation, maintenance, or attempted repair by anyone other than Phoenix Model.

Further, Phoenix Model reserves the right to change or modify this warranty without notice.

DISCLAIMER

Read this disclaimer carefully before using this product. Please strictly follow the instruction manual to assemble and use this.

In that Phoenix Model has no control over the final assembly or material used for final assembly, Phoenix Model is not responsible for loss of use, or other incidental or consequential damages.

Furthermore, Phoenix Model cannot be held liable for personal injury or property damage caused by the use or misuse of Phoenix Model products. By the act of using the user-assembled products, the user accepts all resulting liability.

SAFETY PRECAUTION

- This is not a toy and pilots must be over the age of 14
- Be sure that no other flyers are using your radio frequency.
- Do not smoke near fuel
- Store fuel in a cool, dry place, away from children and pets.
- Wear safety glasses.
- The glow plug clip must be securely attached to the glow plug.
- Do not flip the propeller with your fingers.
- Keep loose clothing and wires away from the propeller.
- Do not start the engine if people are near. Do not stand in line with the side of the propeller.
- Make engine adjustments from behind the propeller only. Do not reach around the spinning propeller.
- Moisture causes damage to electronics. Avoid water exposure to all equipment not specifically designed and protected for this purpose.

IMPORTANT BUILDING NOTES

- Please trial fit all the parts. Make sure you have the correct parts and that they fit and are aligned properly before gluing! This will assure proper assembly. This kit is hand made from natural materials, every plane is unique and minor adjustments may have to be made. However, you should find the fit superior and assembly simple.
- The painted and plastic parts used in this kit are fuel proof. However, they are not tolerant of many harsh chemicals including the following: paint thinner, C/A glue accelerator, C/A glue debonder and acetone. Do not let these chemicals come in contact with the colors on the covering and the plastic parts.
- Some parts included in this kit such as the cowl or wheel pants are made of fiberglass, the fibers of which may cause eye, skin and respiratory tract irritation. Never blow into a part to remove fiberglass dust, as the dust will blow back into your eyes. Always wear safety goggles, a particle mask and rubber gloves when grinding, drilling and sanding fiberglass parts. Vacuum the parts and the work area thoroughly after working with fiberglass parts.

SUGGESTION

To avoid scratching your new airplane, do not unwrap the pieces until they are needed for assembly. Cover your workbench with an old towel or brown paper, both to protect the aircraft and to protect the table. Keep a couple of jars or bowls handy to hold the small parts after you open the bag.

FLIGHT WARNINGS

- Always operate in open areas, away from factories, hospitals, schools, buildings and houses etc.
- NEVER fly your aircraft close to people or built up areas.
- NEVER fly near power lines, aerials or other dangerous areas including airports, motorways etc.
- NEVER fly in wet conditions or on windy or stormy days.
- ALWAYS adjust the engine from behind the propeller, and do not allow any part of your body to be in line with the propeller.
- THE PROPELLER IS DANGEROUS Keep fingers, clothing (ties, shirt sleeves, scarves) or any other loose objects that could be caught or drawn in, away from the propeller. Take care at ALL times.
- NEVER use damaged or deformed propellers or spinners.
- Keep all onlookers (especially small children and animals) well back from the area of operation. This is a flying aircraft, which will cause serious injury in case of impact with a person or animal.
- DO NOT dispose of empty fuel containers on a fire, this can lead to an explosion.

FLIGHT WARNINGS

- When ready to fly, first extend the transmitter aerial.
- Switch on the transmitter.
- Switch on the receiver.
- Check that the wings are correctly fitted to the fuselage.
- Operate the control sticks on the transmitter and check that the control surfaces move freely and in the CORRECT directions.
- Check that the transmitter batteries have adequate power.
- ALWAYS take off into the wind.
- If the model does not respond correctly to the controls, land it as soon as possible and correct the fault.
- ALWAYS land the model INTO the wind, this ensures that the model lands at the slowest possible speed.
- Switch off the receiver.
- Switch off the transmitter.
- Empty the fuel tank after flying, fuel left in the tank can cause corrosion and lead to engine problems.

COVERING TOOLS

- Top Flite® MonoKote® Sealing Iron
- Top Flite Hot Sock Iron Cover
- Top Flite MonoKote Trim Seal Iron
- Top Flite MonoKote Heat Gun

ADHESIVES AND REQUIRED TOOLS

- Thin CA
- 30-minute epoxy
- 6-minute epoxy
- Threadlocker thread locking cement
- Mixing sticks
- Mixing cups (GPMR8056)
- Epoxy brushes
- Denatured alcohol
- Canopy Glue
- Felt-tipped pen or pencil
- Flat screwdriver
- Adjustable wrench
- Drill
- Hobby knife
- Masking tape
- Phillips screwdriver (large)
- Phillips screwdriver (small)
- Ruler
- Sandpaper
- Soldering iron
- Solder
- Hex wrench
- Drill bit: 1/16-inch (1.5mm), 5/64-inch (2mm), 1/8-inch (3,2mm), 3/16-inch (4,8mm), 11/64-inch (4.5mm), 13/64-inch (5,2mm), 1/4-inch (6,4mm)

Academy of Model Aeronautics National Model Aircraft Safety Code**Effective January 1, 2014**

A. GENERAL: A model aircraft is a non-human-carrying aircraft capable of sustained flight in the atmosphere. It may not exceed limitations of this code and is intended exclusively for sport, recreation, education and/or competition. All model flights must be conducted in accordance with this safety code and any additional rules specific to the flying site.

1. Model aircraft will not be flown:
 - (a) In a careless or reckless manner.
 - (b) At a location where model aircraft activities are prohibited.
2. Model aircraft pilots will:
 - (a) Yield the right of way to all human-carrying aircraft.
 - (b) See and avoid all aircraft and a spotter must be used when appropriate. (AMA Document #540-D.)
 - (c) Not fly higher than approximately 400 feet above ground level within three (3) miles of an airport without notifying the airport operator.
 - (d) Not interfere with operations and traffic patterns at any airport, heliport or seaplane base except where there is a mixed use agreement.
 - (e) Not exceed a takeoff weight, including fuel, of 55 pounds unless in compliance with the AMA Large Model Airplane program. (AMA Document 520-A.)
 - (f) Ensure the aircraft is identified with the name and address or AMA number of the owner on the inside or affixed to the outside of the model aircraft. (This does not apply to model aircraft flown indoors.)
 - (g) Not operate aircraft with metal-blade propellers or with gaseous boosts except for helicopters operated under the provisions of AMA Document #555.
 - (h) Not operate model aircraft while under the influence of alcohol or while using any drug that could adversely affect the pilot's ability to safely control the model.
 - (i) Not operate model aircraft carrying pyrotechnic devices that explode or burn, or any device which propels a projectile or drops any object that creates a hazard to persons or property.

Exceptions:

- Free Flight fuses or devices that burn producing smoke and are securely attached to the model aircraft during flight.
- Rocket motors (using solid propellant) up to a G-series size may be used provided they remain attached to the model during flight. Model rockets may be flown in accordance with the National Model Rocketry Safety Code but may not be launched from model aircraft.

- Officially designated AMA Air Show Teams (AST) are authorized to use devices and practices as defined within the Team AMA Program Document. (AMA Document #718.)
- (j) Not operate a turbine-powered aircraft, unless in compliance with the AMA turbine regulations. (AMA Document #510-A.)
- 3. Model aircraft will not be flown in AMA sanctioned events, air shows or model demonstrations unless:
 - (a) The aircraft, control system and pilot skills have successfully demonstrated all maneuvers intended or anticipated prior to the specific event.
 - (b) An inexperienced pilot is assisted by an experienced pilot.
- 4. When and where required by rule, helmets must be properly worn and fastened. They must be OSHA, DOT, ANSI, SNELL or NOCSAE approved or comply with comparable standards.
- B. RADIO CONTROL (RC)
 - 1. All pilots shall avoid flying directly over unprotected people, vessels, vehicles or structures and shall avoid endangerment of life and property of others.
 - 2. A successful radio equipment ground-range check in accordance with manufacturer's recommendations will be completed before the first flight of a new or repaired model aircraft.
 - 3. At all flying sites a safety line(s) must be established in front of which all flying takes place. (AMA Document #706.)
 - (a) Only personnel associated with flying the model aircraft are allowed at or in front of the safety line.
 - (b) At air shows or demonstrations, a straight safety line must be established.
 - (c) An area away from the safety line must be maintained for spectators.
 - (d) Intentional flying behind the safety line is prohibited.
 - 4. RC model aircraft must use the radio-control frequencies currently allowed by the Federal Communications Commission (FCC). Only individuals properly licensed by the FCC are authorized to operate equipment on Amateur Band frequencies.
 - 5. RC model aircraft will not knowingly operate within three (3) miles of any pre-existing flying site without a frequency-management agreement. (AMA Documents #922 and #923.)
 - 6. With the exception of events flown under official AMA Competition Regulations, excluding takeoff and landing, no powered model may be flown outdoors closer than 25 feet to any individual, except for the pilot and the pilot's helper(s) located at the flightline.
 - 7. Under no circumstances may a pilot or other person touch an outdoor model aircraft in flight while it is still under power, except to divert it from striking an individual.
 - 8. RC night flying requires a lighting system providing the pilot with a clear view of the model's attitude and orientation at all times. Hand-held illumination systems are inadequate for night flying operations.
 - 9. The pilot of an RC model aircraft shall:
 - (a) Maintain control during the entire flight, maintaining visual contact without enhancement other than by corrective lenses prescribed for the pilot.
 - (b) Fly using the assistance of a camera or First-Person View (FPV) only in accordance with the procedures outlined in AMA Document #550.
 - (c) Fly using the assistance of autopilot or stabilization system only in accordance with the procedures outlined in AMA Document #560.
- C. FREE FLIGHT
 - 1. Must be at least 100 feet downwind of spectators and automobile parking when the model aircraft is launched.
 - 2. Launch area must be clear of all individuals except mechanics, officials, and other fliers.
 - 3. An effective device will be used to extinguish any fuse on the model aircraft after the fuse has completed its function.
- D. CONTROL LINE
 - 1. The complete control system (including the safety thong where applicable) must have an inspection and pull test prior to flying.
 - 2. The pull test will be in accordance with the current Competition Regulations for the applicable model aircraft category.
 - 3. Model aircraft not fitting a specific category shall use those pull-test requirements as indicated for Control Line Precision Aerobatics.
 - 4. The flying area must be clear of all utility wires or poles and a model aircraft will not be flown closer than 50 feet to any above-ground electric utility lines.
 - 5. The flying area must be clear of all nonessential participants and spectators before the engine is started.

IMPORTANT NOTES

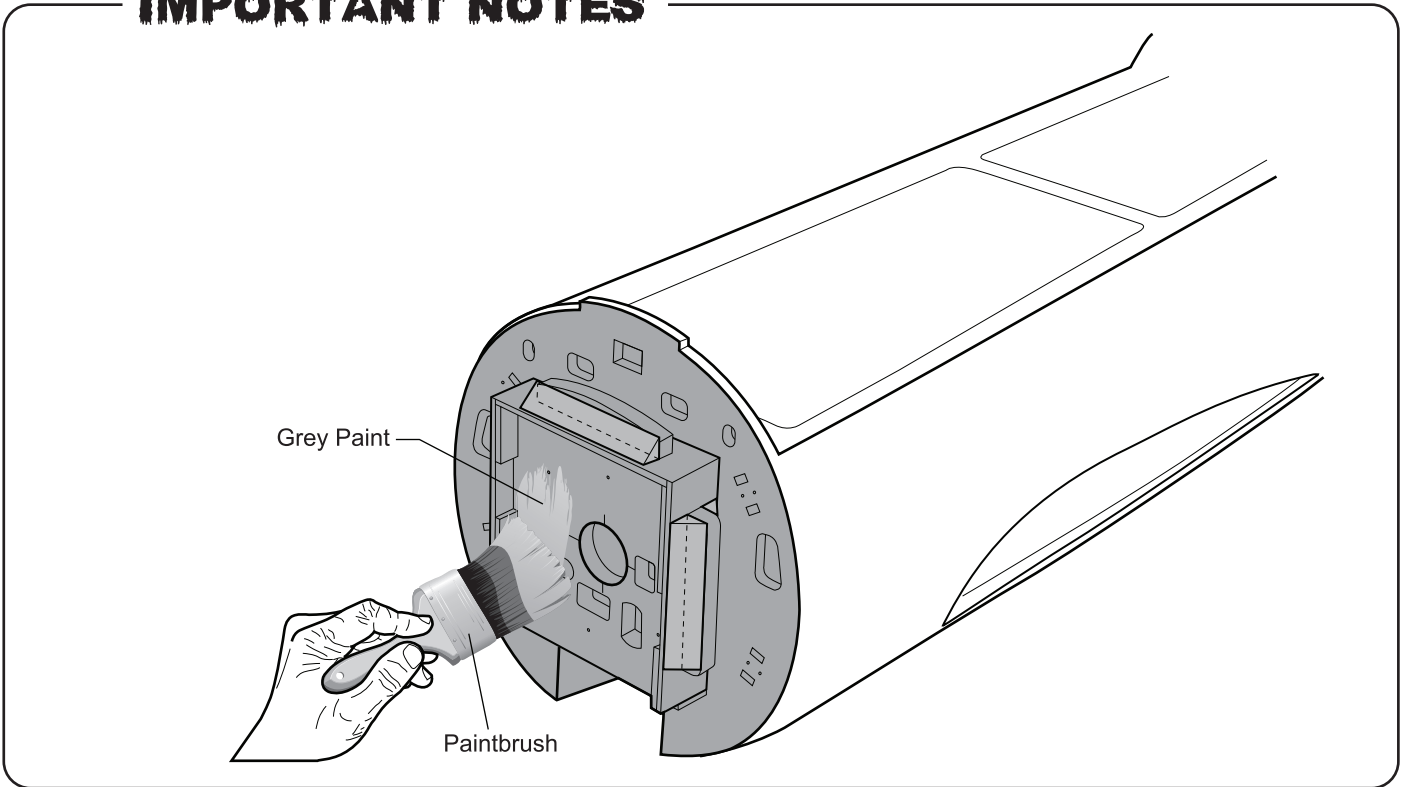



PREPARATIONS

Use a covering iron with a covering sock on high heat to tighten the covering if necessary. Apply pressure over sheeted areas to thoroughly bond the covering to the wood.

INSTALLING THE AILERONS AND FLAPS

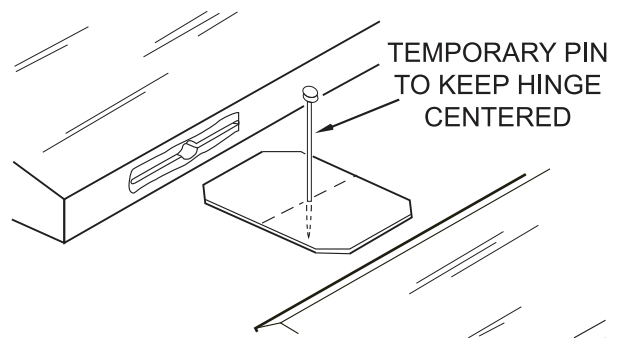
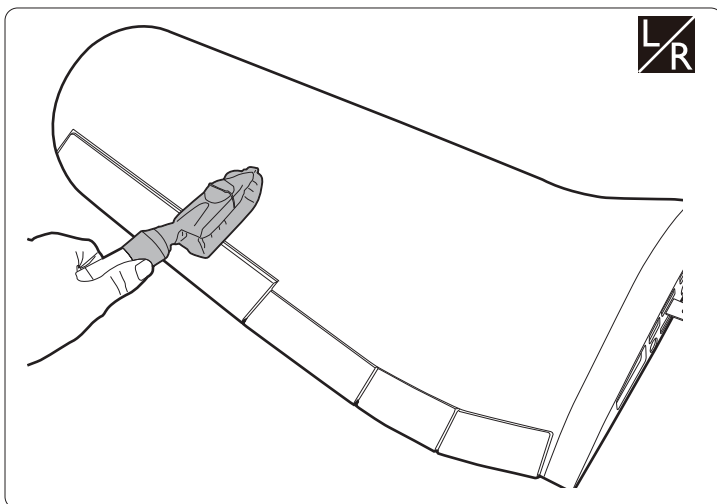
1. Test fit the ailerons to the wing with the hinges. If the hinges don't remain centered, stick a pin through the middle of the hinge to hold it in position.
2. Apply six drops of thin CA to the top and bottom of each hinge. Do not use CA accelerator. After the CA has fully hardened, test the hinges by pulling on the aileron.



 Assemble left and right sides the same way

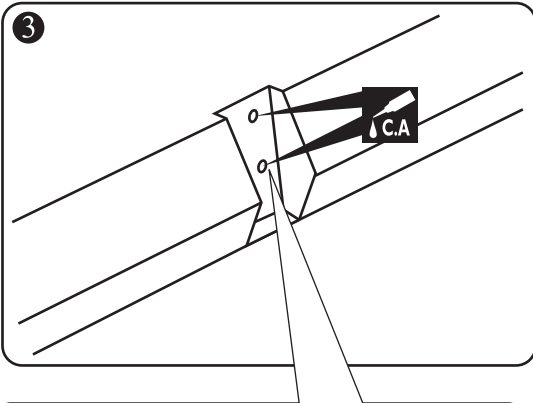
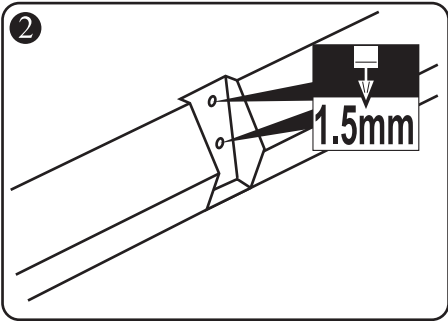
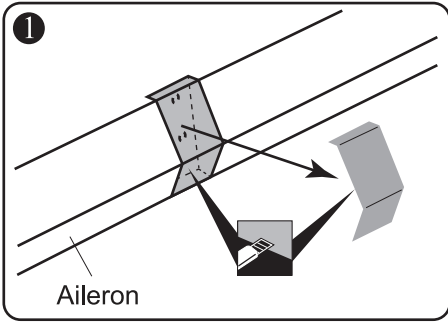

! WARNINGS

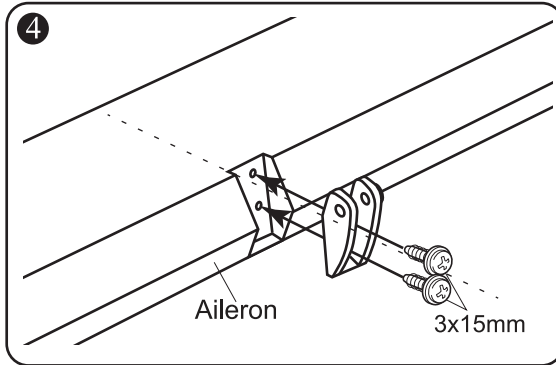
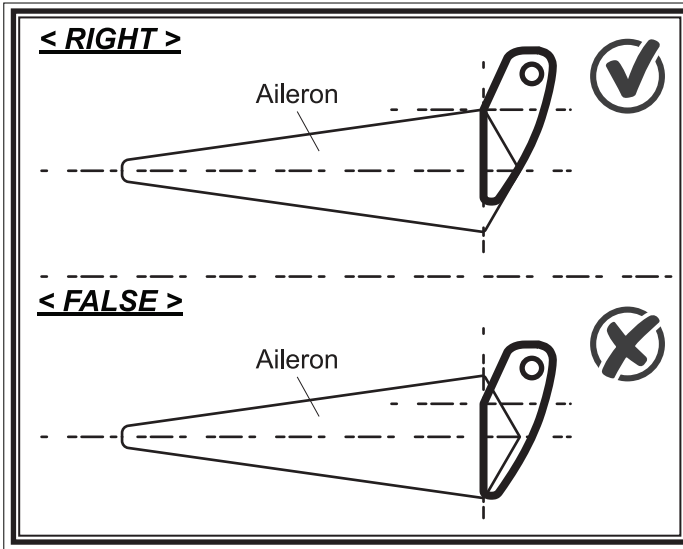

! Warning!

► Please note that C.A glue must be apply to these holes before screw the control horn to the aileron. If not, it comes off during flights, you may lose control of your airplane, resulting in an accident !

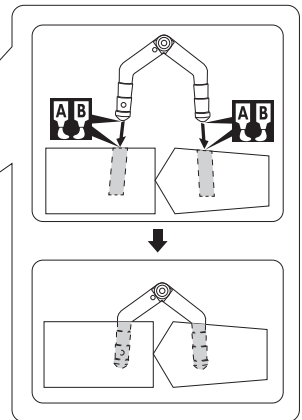
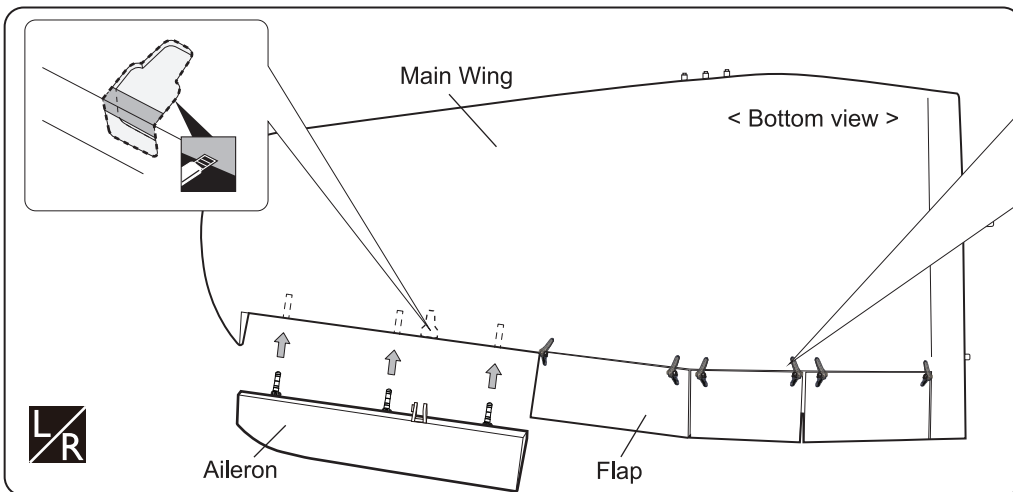

Apply instant glue (CA glue, super glue).

Apply epoxy glue.

Assemble left and right sides the same way

Cut off shaded portion

Drill holes with the specified diameter.



Warning! Make certain the hinges are adequately secured with glue. If they come loose in flight accidents may result.

AB Apply epoxy glue.

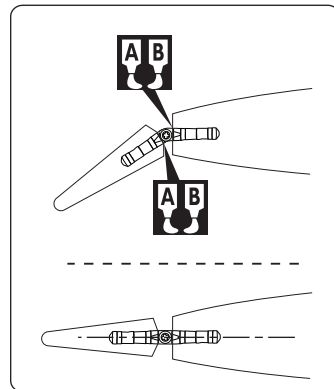

INSTALLING THE AILERONS AND FLAPS

SERVOS

1. Install the rubber grommets and brass eyelets onto the aileron servo.
2. Using a modeling knife, remove the covering from over the pre-cut servo arm exit hole on the aileron servo tray / hatch. This hole will allow the servo arm to pass through when installing the aileron pushrods.
3. Place the servo into the servo tray. Center the servo within the tray and drill pilot holes through the block of wood for each of the four mounting screws provided with the servo.
4. Using the thread as a guide and using masking tape, tape the servo lead to the end of the thread: carefully pull the thread out. When you have pulled the servo lead out, remove the masking tape and the servo lead from the thread.
5. Place the aileron servo tray / hatch into the servo box on the bottom of the wing and drill pilot holes through the tray and the servo box for each of the four mounting screws. Secure the servo tray in place using the mounting screws provided.
6. Repeat step # 2 - # 5 to install the second aileron servo in the opposite wing half.

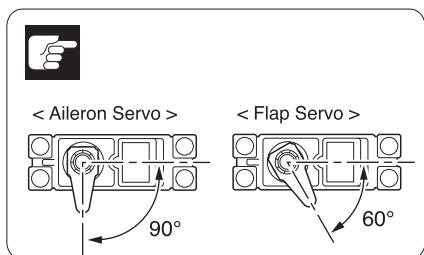
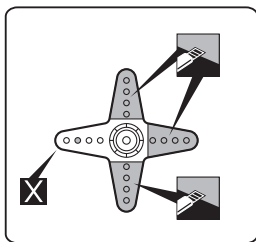
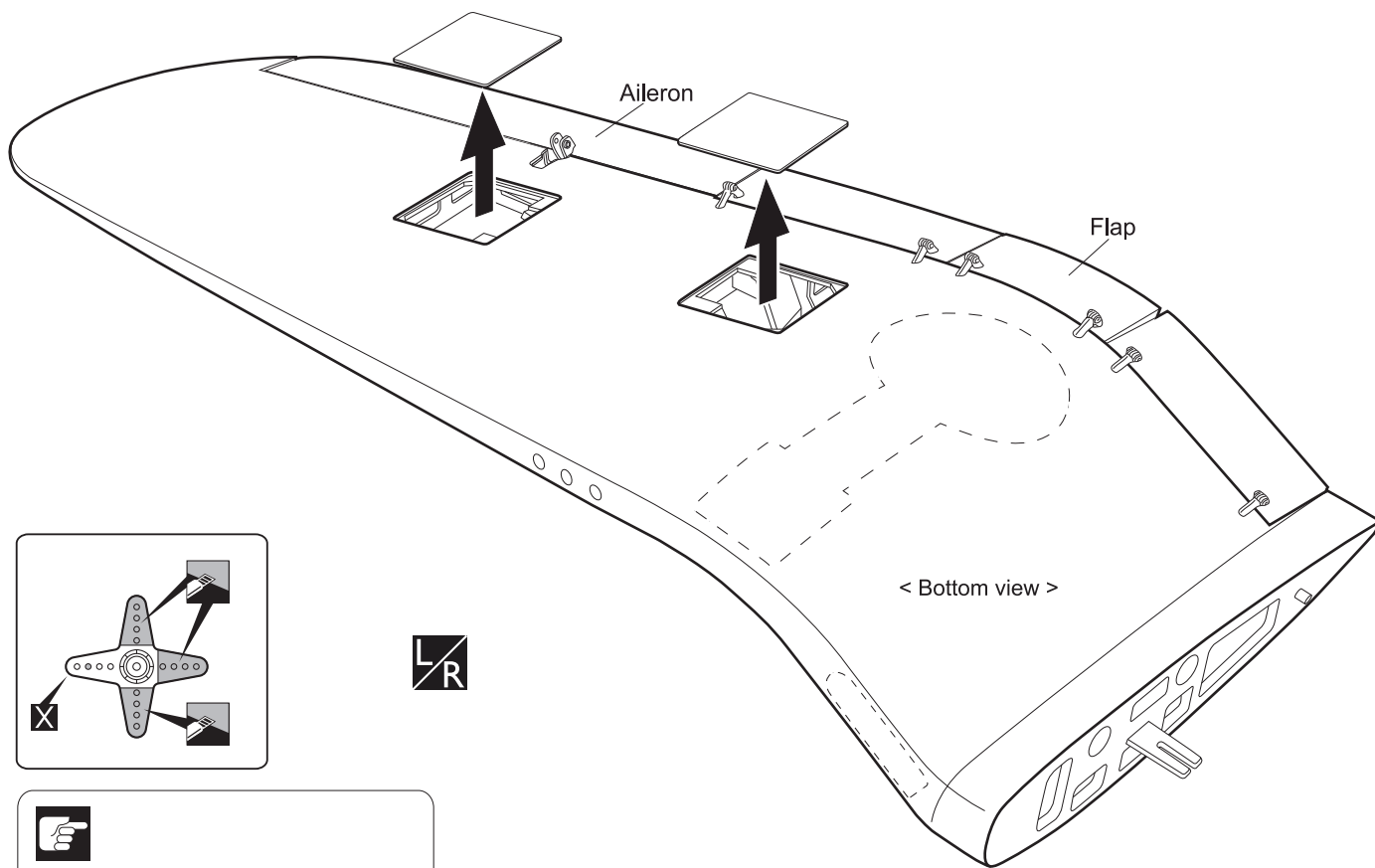

- Pay close attention here!
- Cut off shaded portion
- Assemble left and right sides the same way



Warning!

▶ Set all screws securely. If they come off during flight you will lose control of your aircraft!

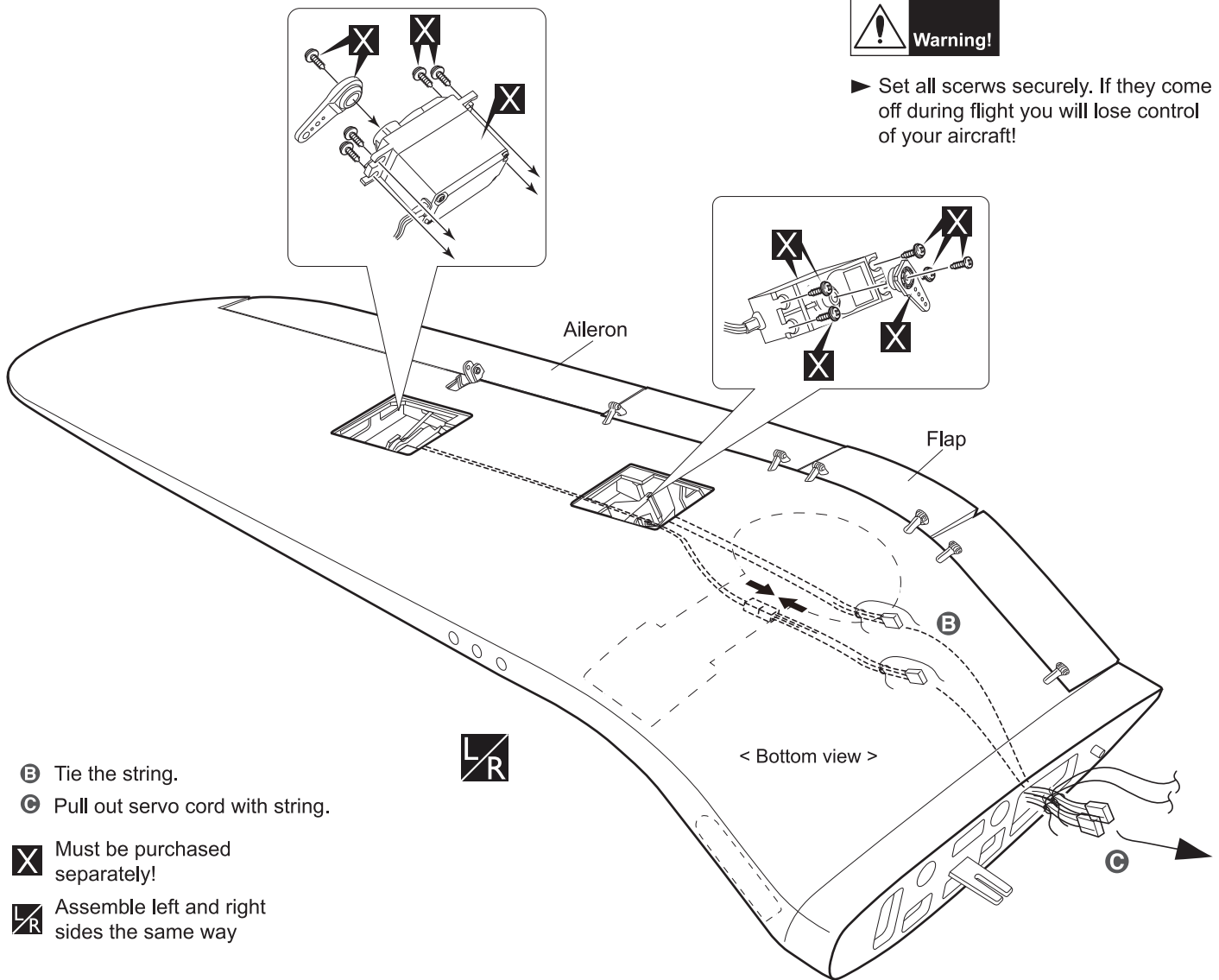

- B** Tie the string.
- C** Pull out servo cord with string.
- X** Must be purchased separately!
- LR** Assemble left and right sides the same way

INSTALLING THE AILERONS AND FLAPS LINKAGES

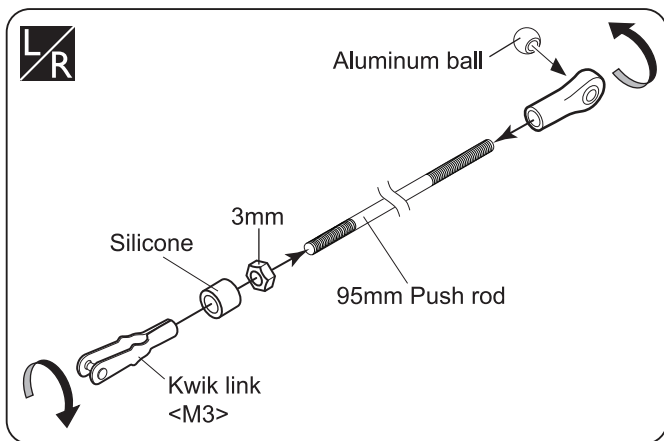

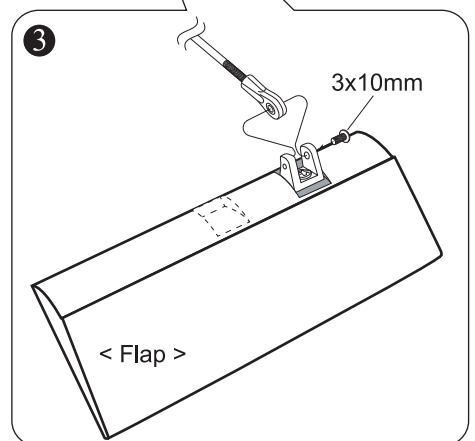
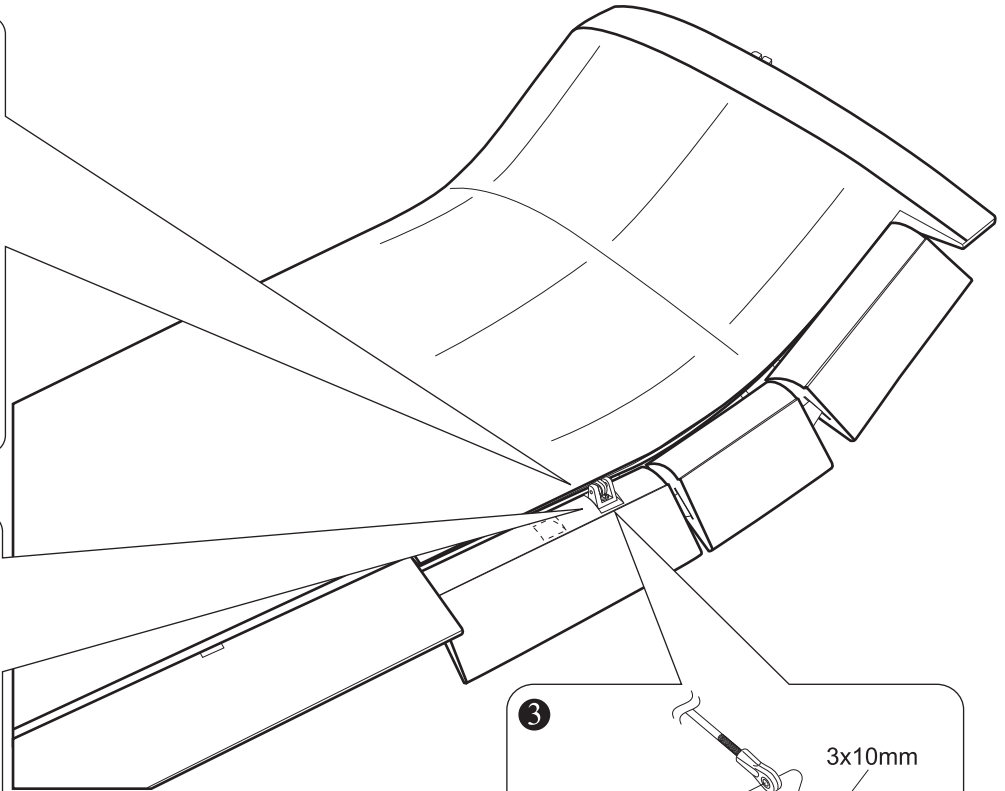
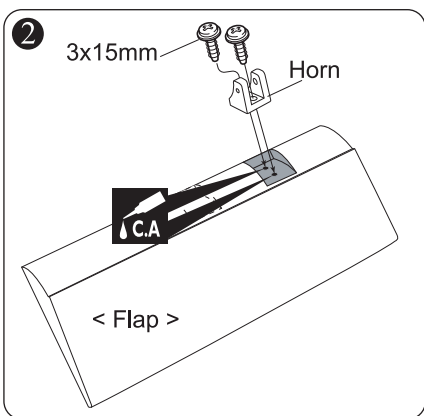
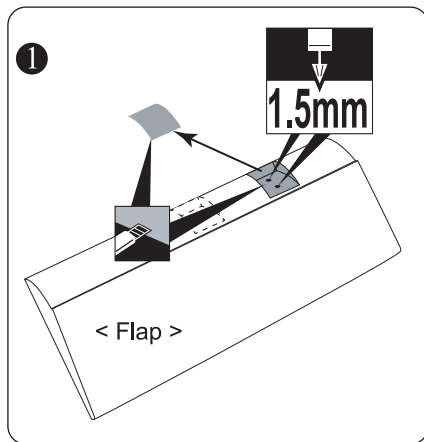
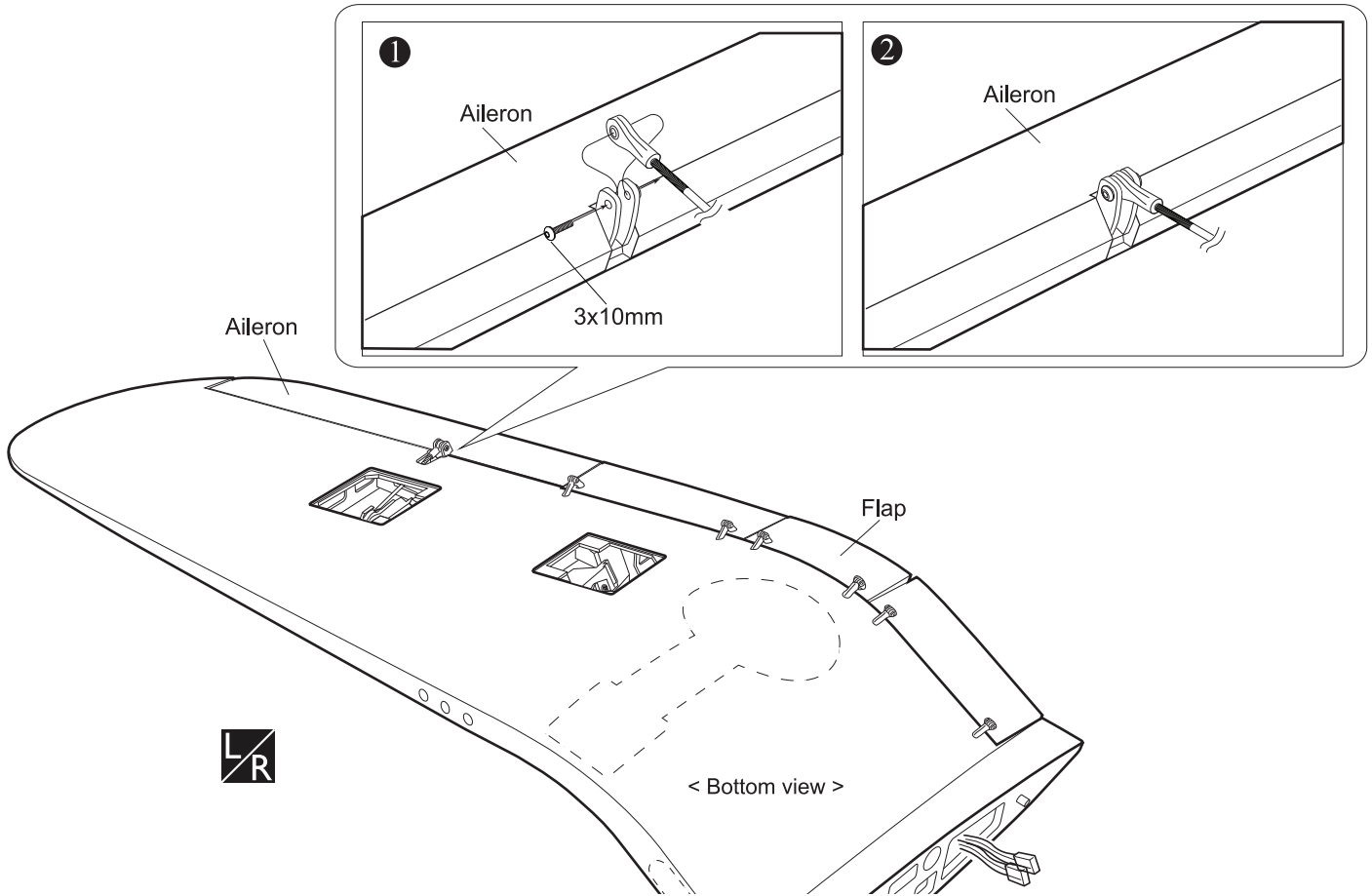

LR Assemble left and right sides the same way

| Control horn <Flap> | | Control horn <Aileron> | |
|-----------------------|---|------------------------|---|
| | 2 | | 2 |
| 3 x 10mm Button Screw | 2 | 3 x 10mm Button Screw | 2 |
| | 2 | | 2 |
| Metal kwik link (M3) | 2 | Metal kwik link (M3) | 2 |
| | 2 | | 2 |
| Silicone | 2 | Silicone | 2 |
| | 2 | | 2 |
| Aluminum ball | 2 | Aluminum ball | 2 |
| | 2 | | 2 |
| 3 x 15mm TP Screw | 2 | 3 x 15mm TP Screw | 2 |
| | 2 | | 2 |
| 3 x 95mm Push rod | 4 | 3 x 95mm Push rod | 4 |
| | 4 | | 4 |
| | 2 | | 2 |



 Apply instant glue (CA glue, super glue).

 Assemble left and right sides the same way

 Cut off shaded portion

 Drill holes with the specified diameter.

2 x 10mm TP Screw
 16

2x10mm

Aileron



2x10mm

Flap

< Bottom view >

Push rod
 Silicone
 3mm Nut
 Kwik link <M3>

Silicone
 Kwik link <M3>

 Cut off shaded portion
 Must be purchased separately!
 Assemble left and right sides the same way

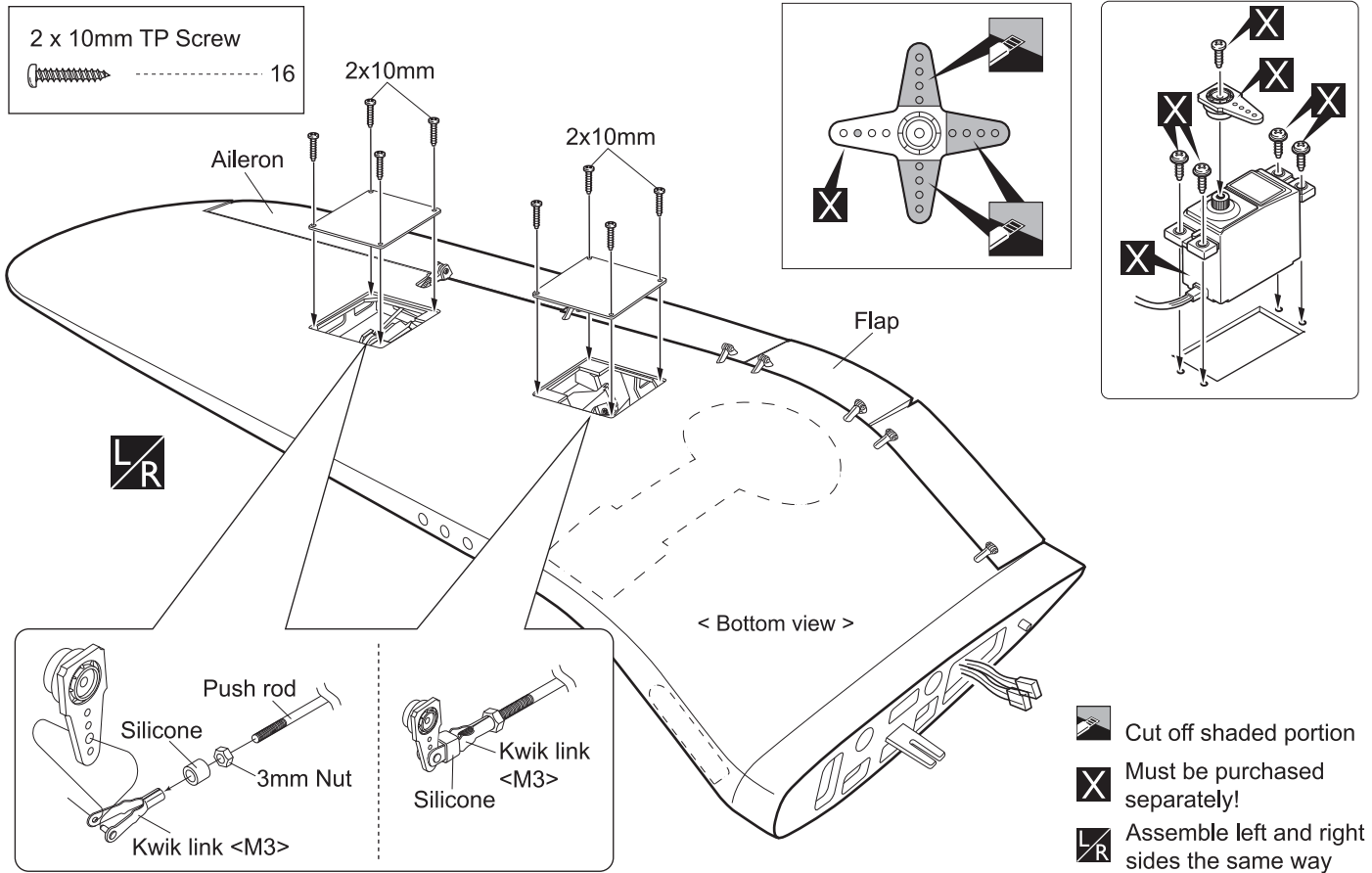

INSTALLING THE PLASTIC COVER

Plastic cover
 2

 **Warning!**
 ▶ Do not overlook this symbol!

Aileron

Flap

< Bottom view >

Apply instant glue (CA glue, super glue).

Cut off shaded portion

Assemble left and right sides the same way

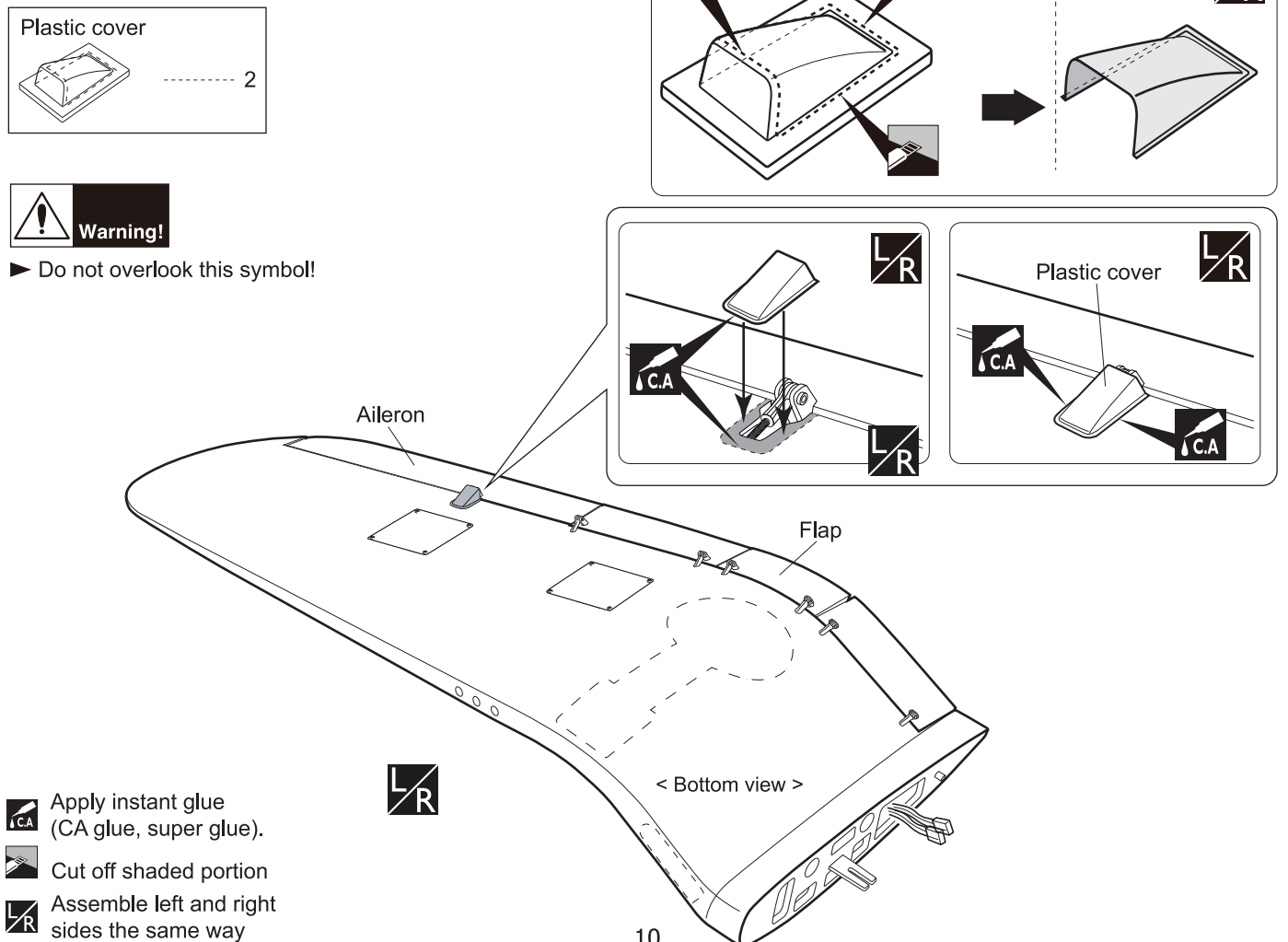



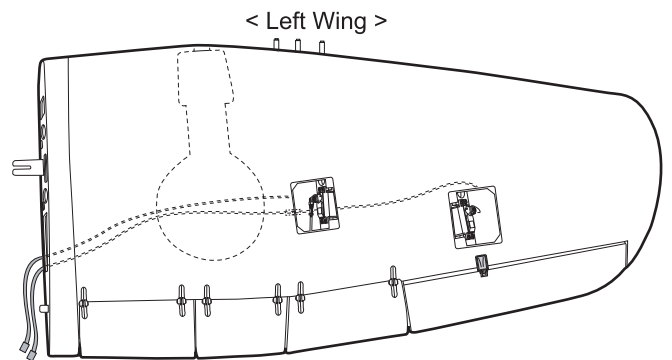
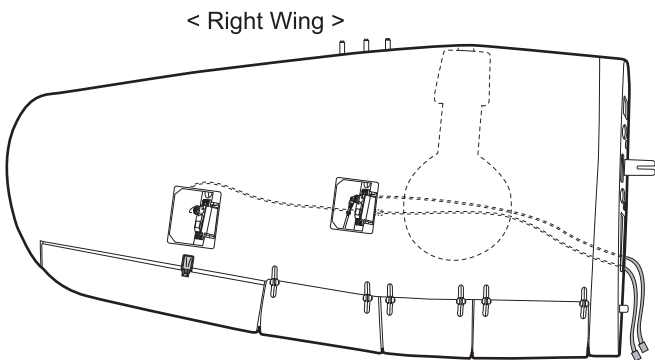
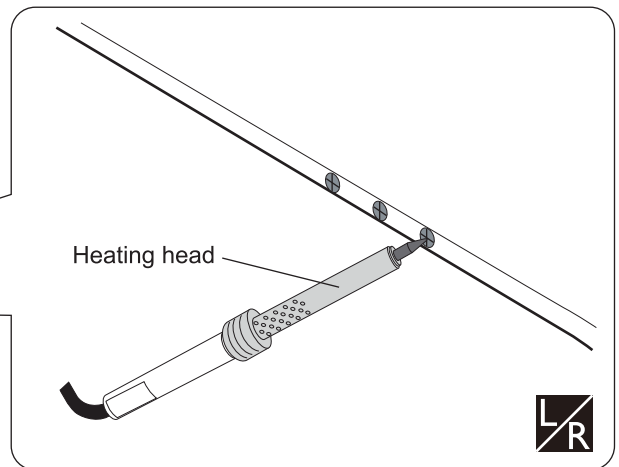
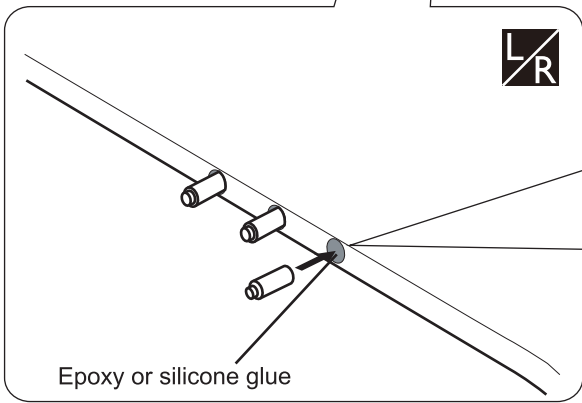
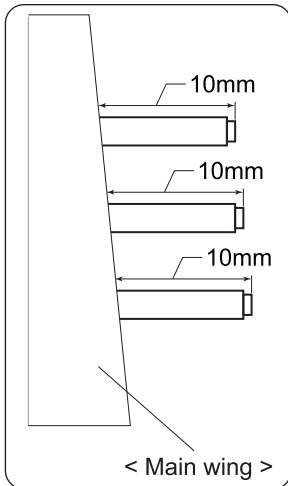
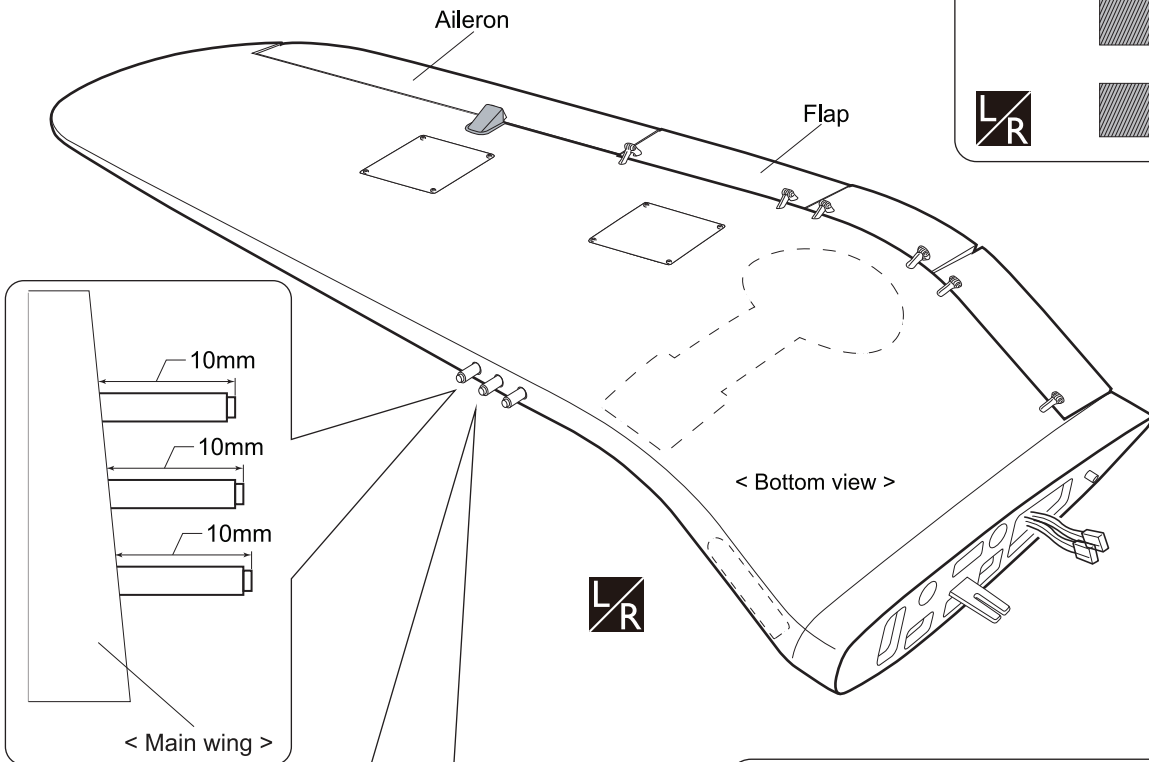
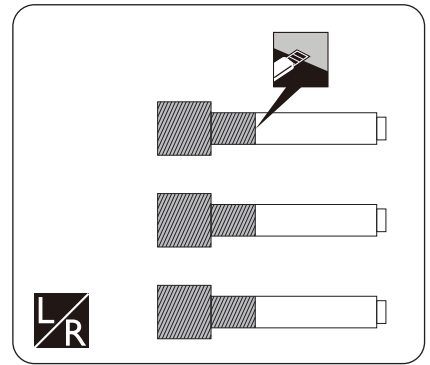
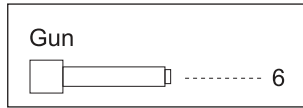

INSTALLING THE GUN





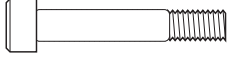

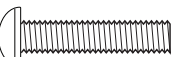
► Set all screws securely. If they come off during flight you will lose control of your aircraft!

- Cut off shaded portion
- Assemble left and right sides the same way

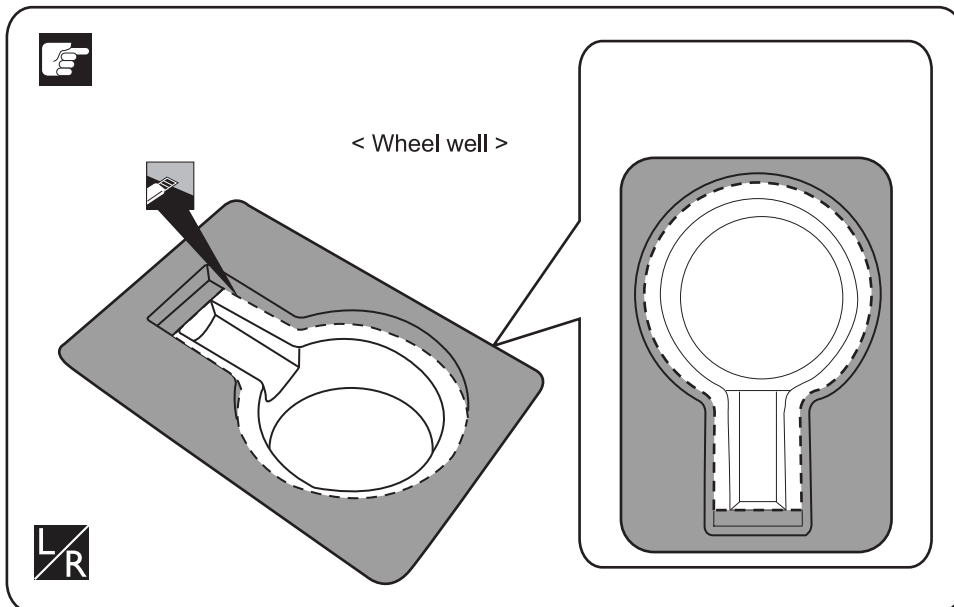
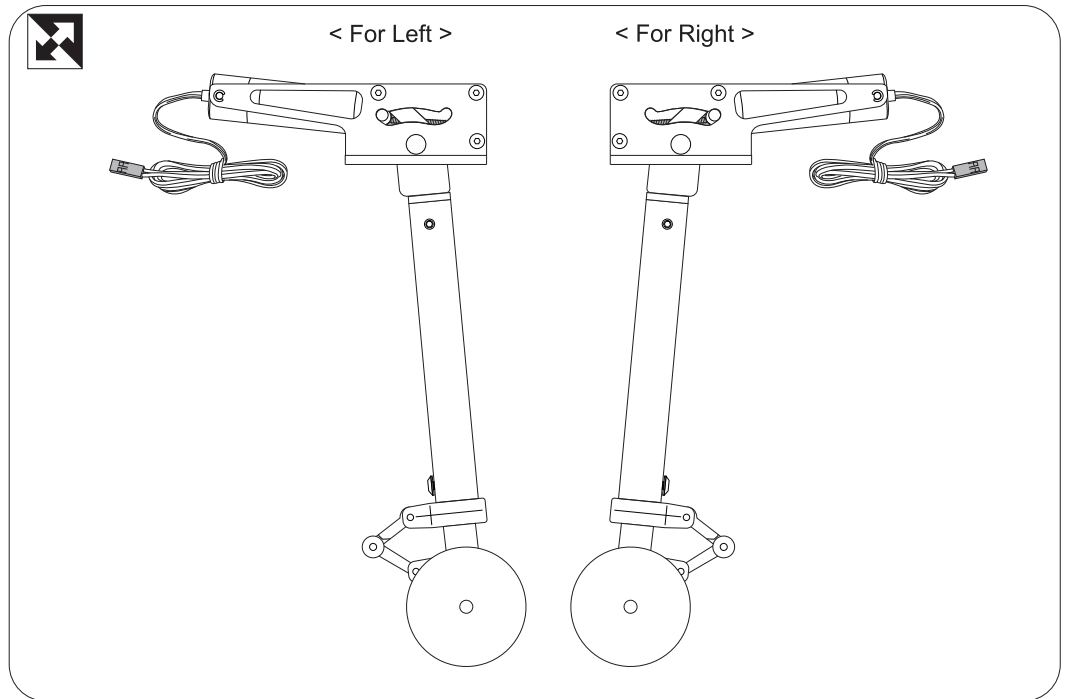
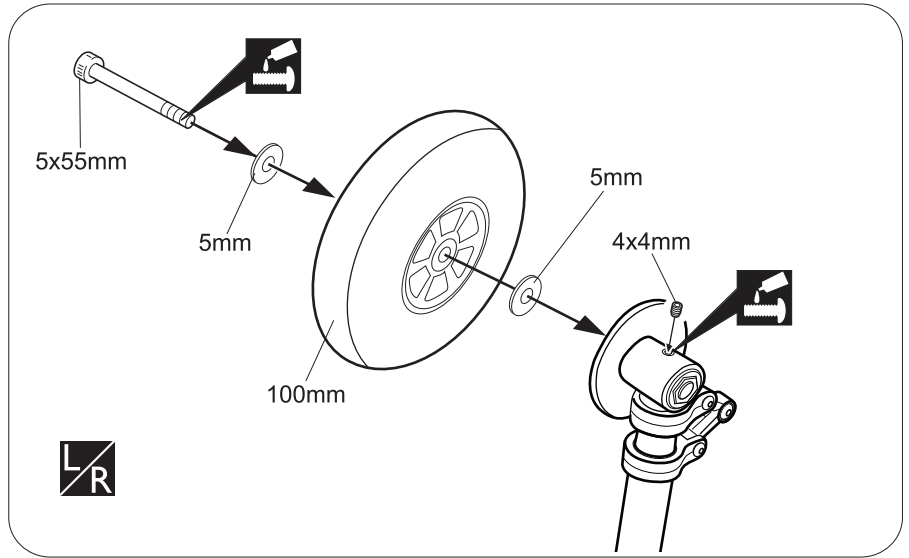

INSTALLING THE MAIN LANDING GEAR

- 5 x 55mm Cap Screw  .. 2
- 5mm Washer  4
- 4x4mm Set Screw  2
- 4 x 20mm Button Screw  8
- 4mm Washer  8
- 4mm Spring Washer  8

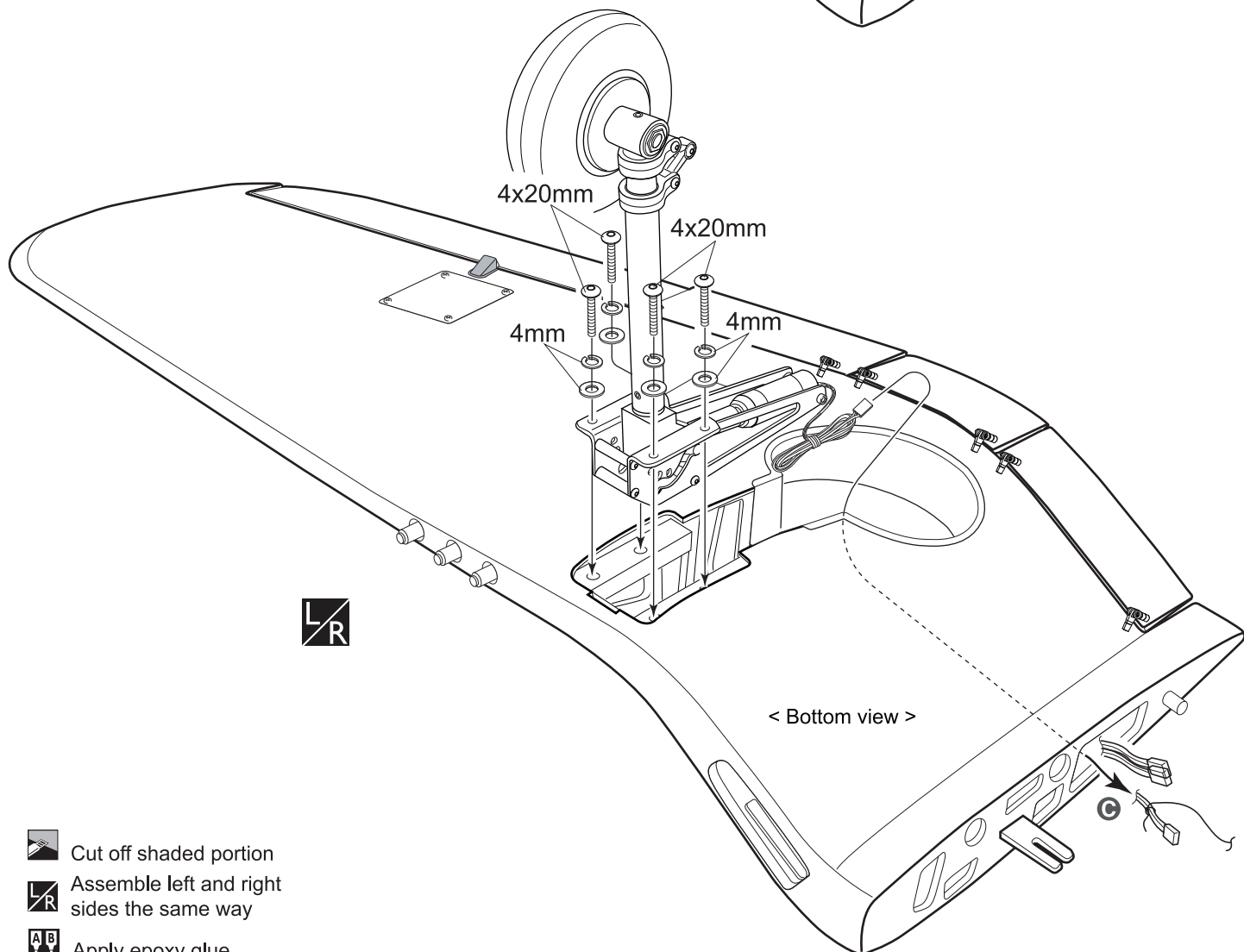
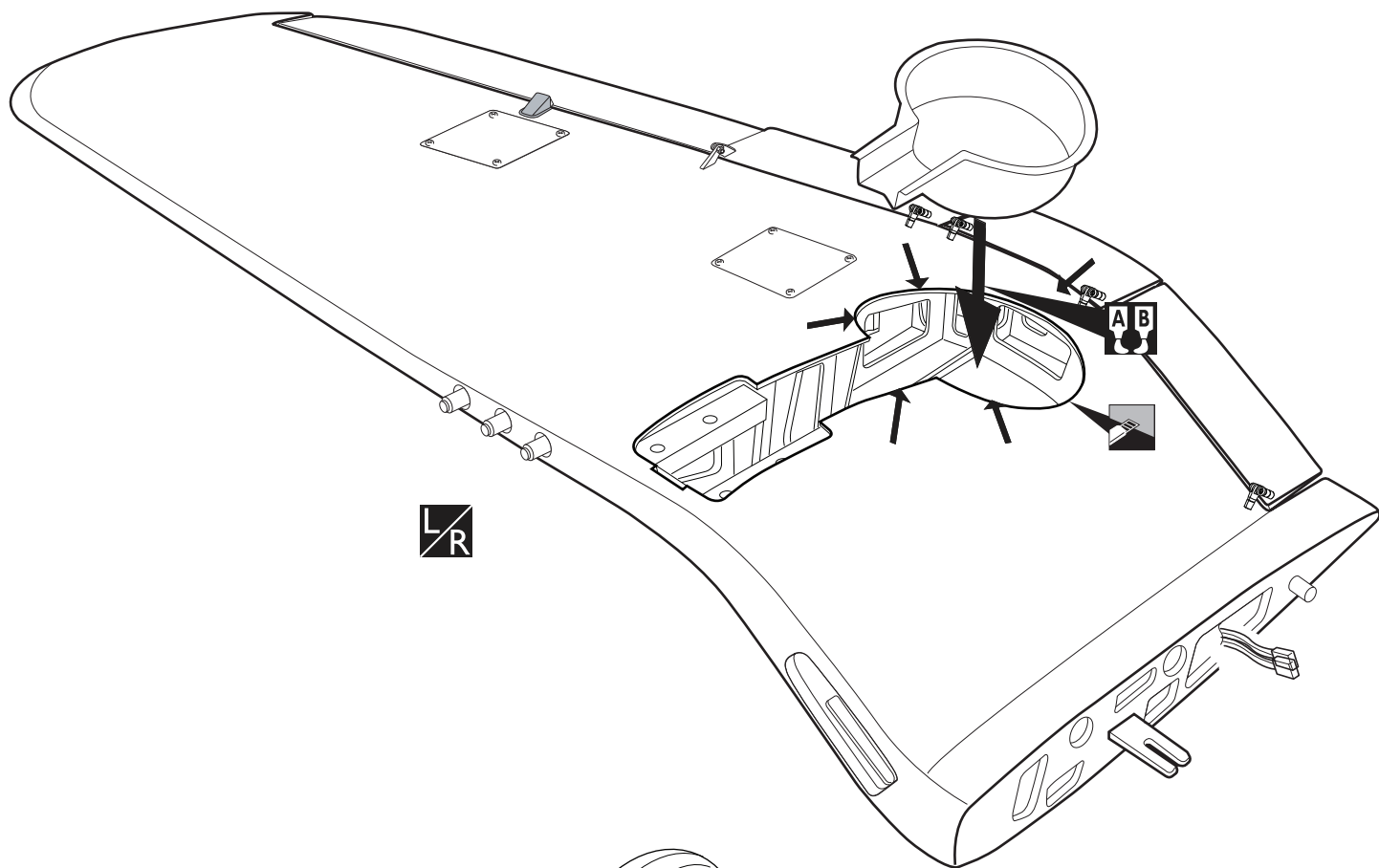

-  Pay close attention here!
-  Cut off shaded portion
-  Assemble left and right sides the same way
-  Apply threadlocker (screw cement).



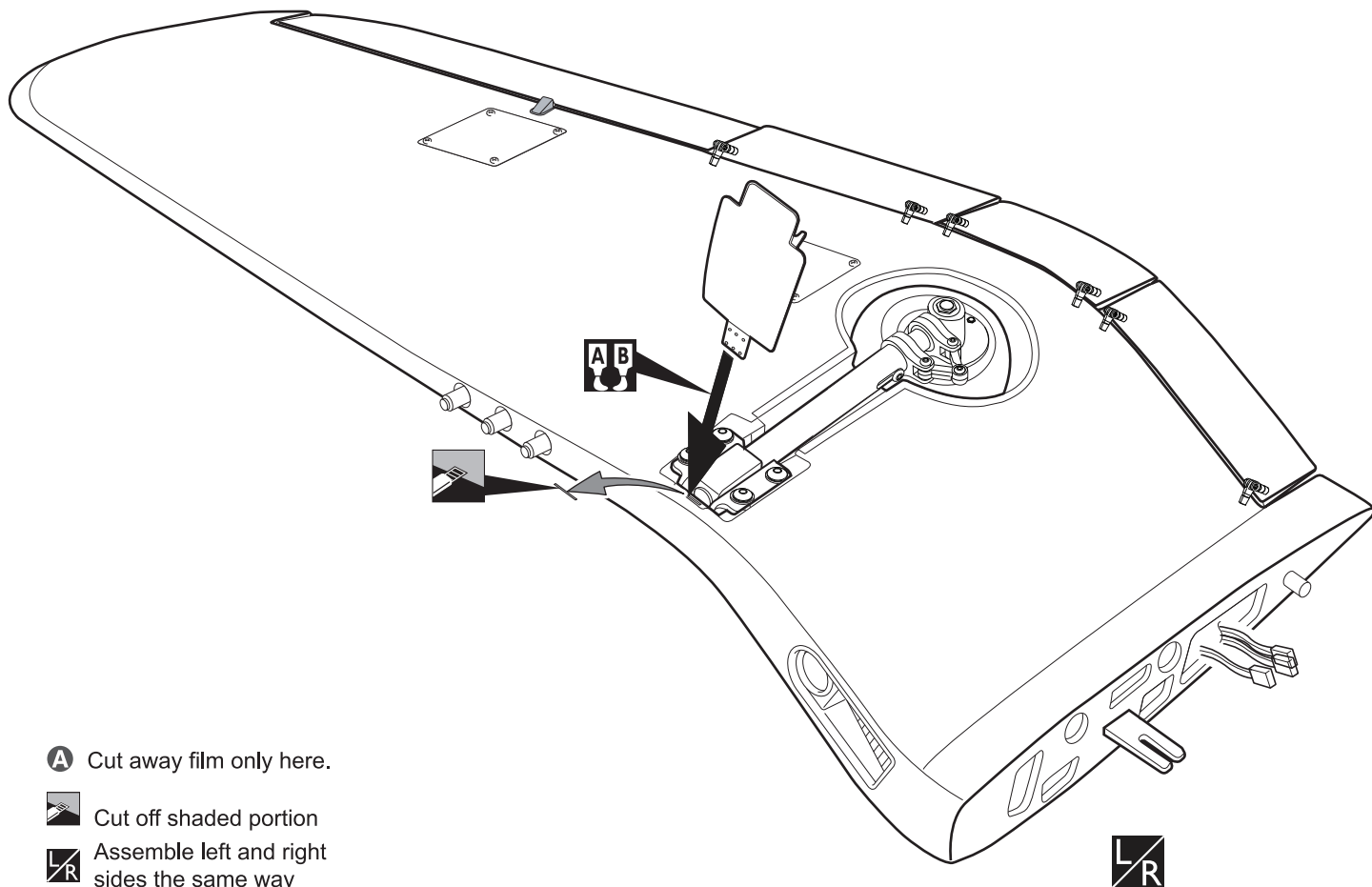
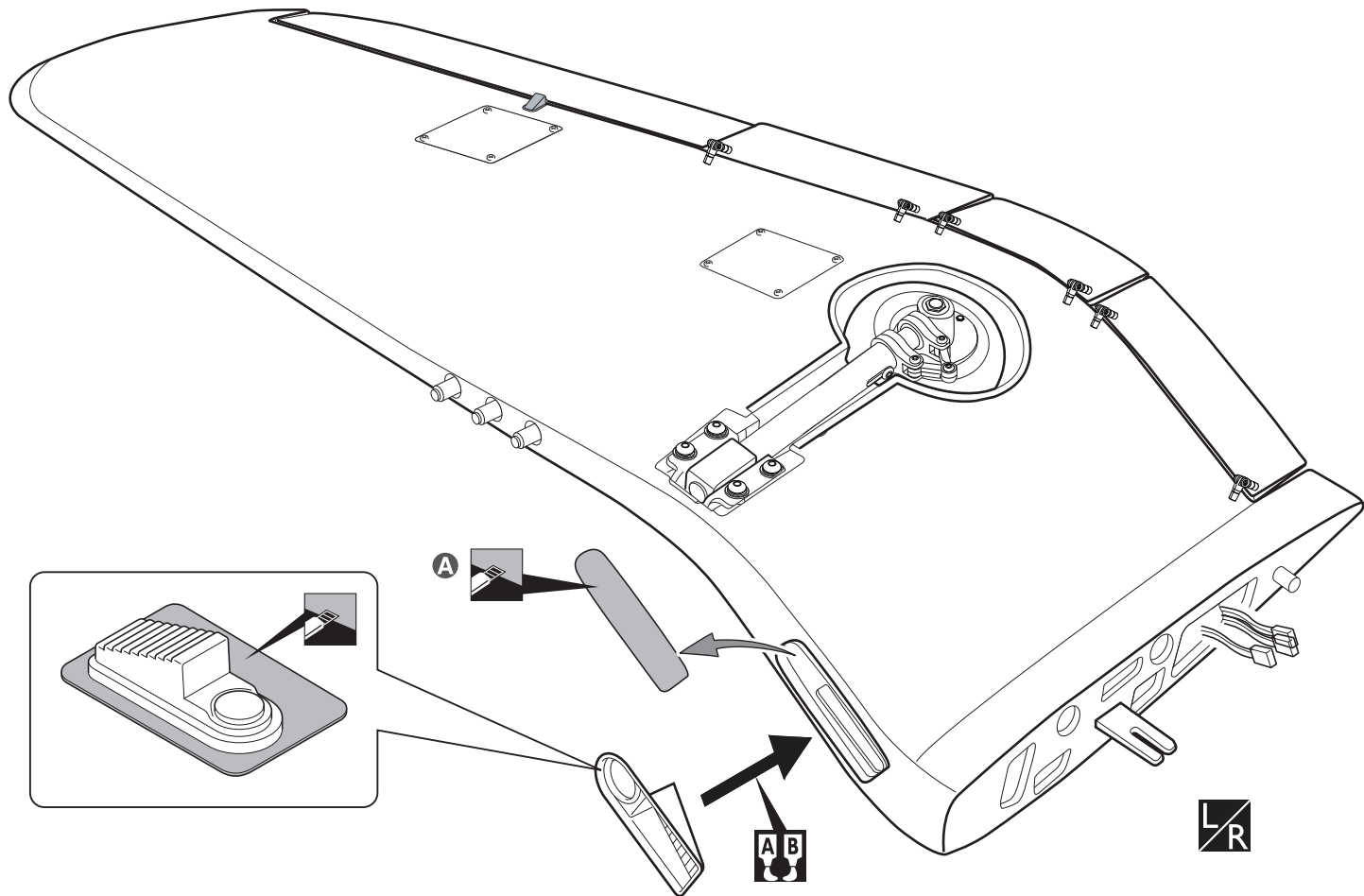

-  Cut off shaded portion
-  Assemble left and right sides the same way
-  Apply epoxy glue

Ⓒ Pull out servo cord with string.



A Cut away film only here.

 Cut off shaded portion

 Assemble left and right sides the same way

 Apply epoxy glue

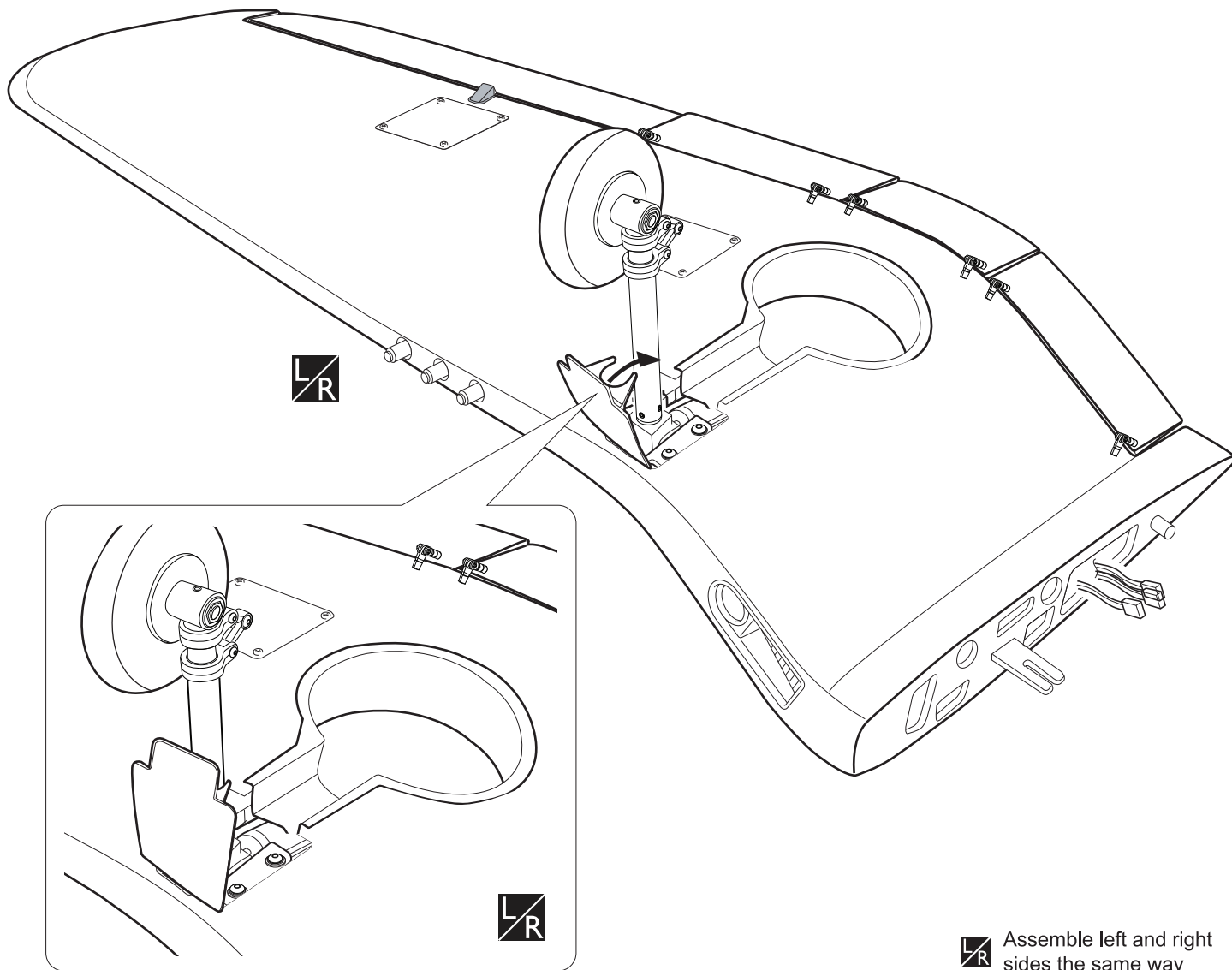

Assemble left and right sides the same way

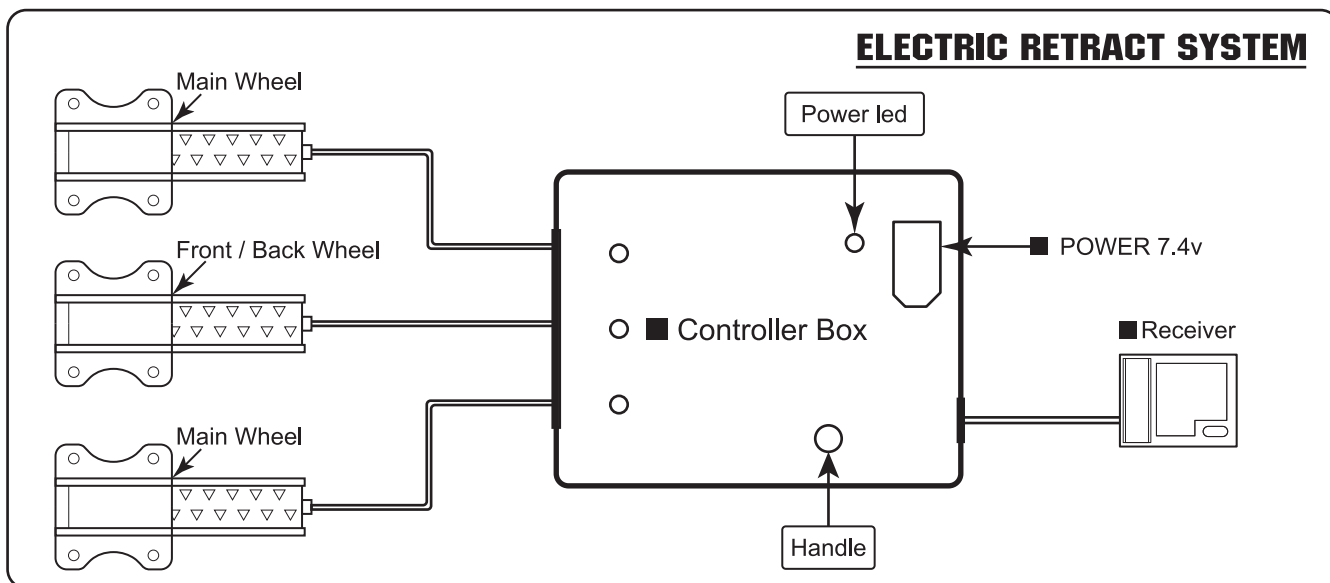

SECURE THE WING TO THE FUSELAGE

Attach the wings to the fuselage and secure the wing panels.

1. Trim the circular areas of covering over each wing screw.
2. Loosen each screw approximately 4mm. (It is not necessary, nor recommended, to completely remove the wing screws.)

3. Trim the covering from the slots for the wing alignment spares on each side of the top of the fuselage.
4. Slide the wings into the fuselage. Once flush adjust the wing screws as necessary and tighten once in position.

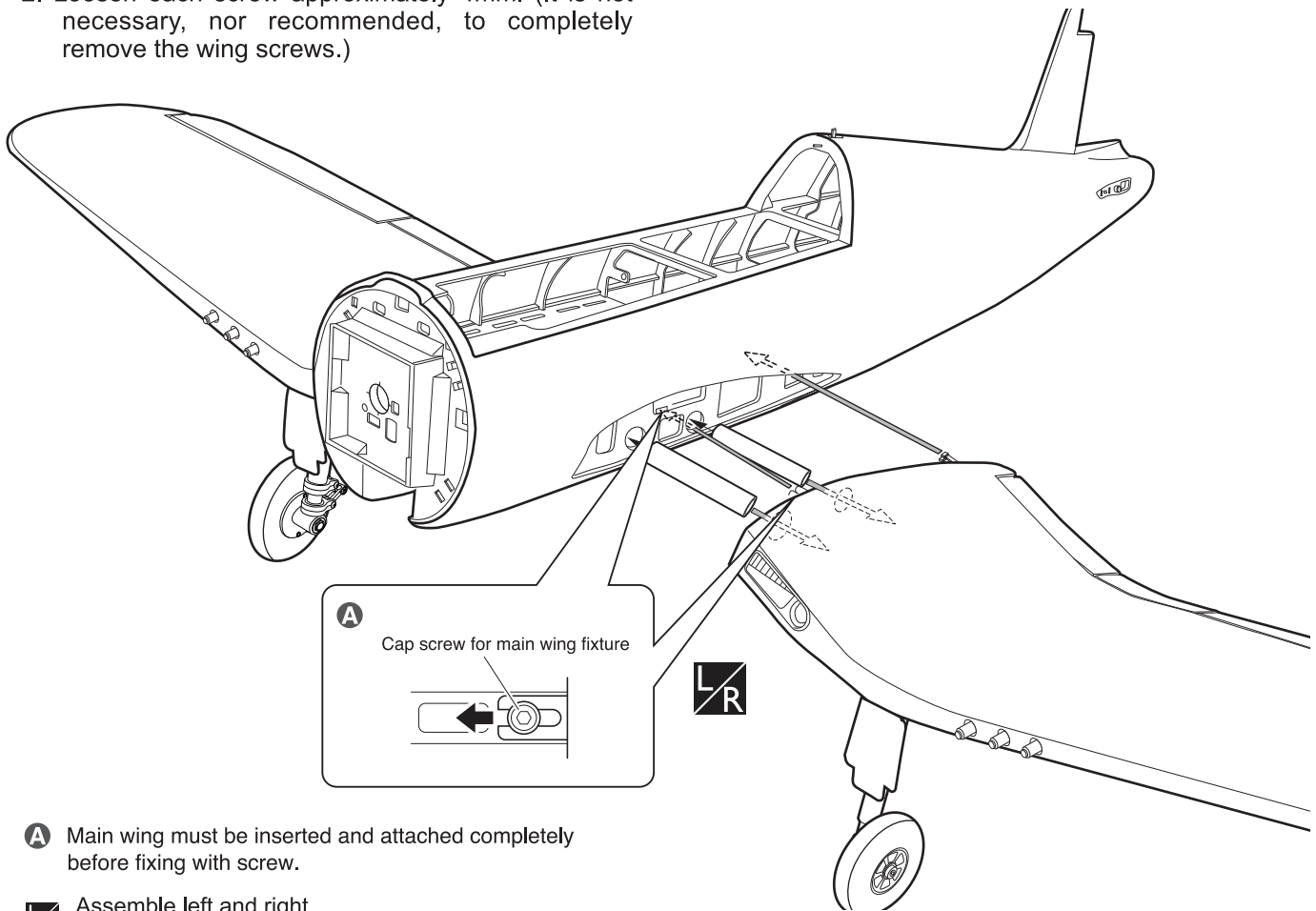

- A** Main wing must be inserted and attached completely before fixing with screw.

- LR** Assemble left and right sides the same way.

HORIZONTAL STABILIZER INSTALLATION

1. Using a modeling knife, cut away the covering from the fuselage for the stabilizer and remove it.
2. Draw a center line onto the horizontal stabilizer.
3. Check the fit of the horizontal stabilizer in its slot. Make sure the horizontal stabilizer is square and centered to the fuselage by taking measurements, but don't glue anything yet.
4. With the horizontal stabilizer correctly aligned, mark the shape of the fuselage on the top and bottom of the tail plane using a water soluble / non-permanent felt-tip pen.
5. Remove the stabilizer. Using the lines you just drew as a guide, carefully remove the covering from between them using a modeling knife.

6. When you are sure that everything is aligned correctly, mix up a generous amount of 30 minute epoxy. Apply a thin layer to the top and bottom of the stabilizer mounting area and to the stabilizer mounting platform sides in the fuselage. Slide the stabilizer in place and re-align. Double check all of your measurements one more time before the epoxy cures. Remove any excess epoxy using a paper towel and rubbing alcohol and hold the stabilizer in place with T-pins or masking tape.
7. After the epoxy has fully cured, remove the masking tape or T-pins used to hold the stabilizer in place and carefully inspect the glue joints. Use more epoxy to fill in any gaps that were not filled previously and clean up the excess using a paper towel and rubbing alcohol.
8. Installing the elevator using C.A glue as installing the aileron.

! When cutting through the covering to remove it, cut with only enough pressure to only cut through the covering it's self. Cutting into the balsa structure may weaken it. This could lead to possible failure during flight.



Warning!

- ▶ Make certain plane is aligned accurately per the diagram. A mis-aligned plane can fly erratically and cause accidents.

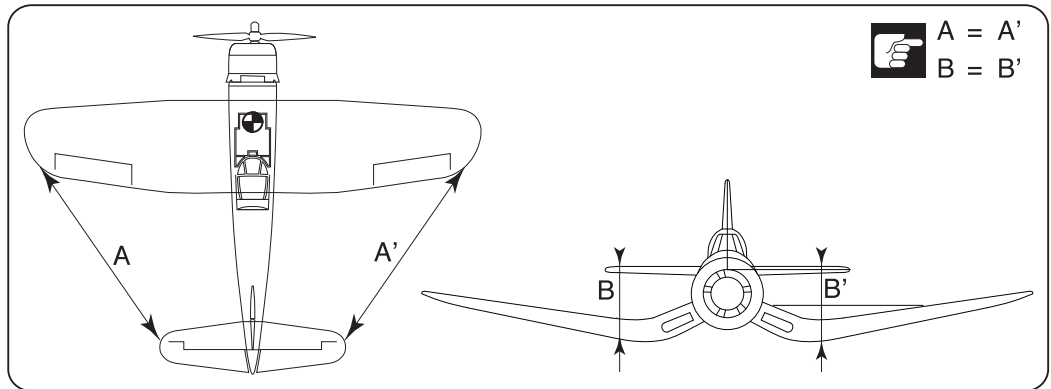
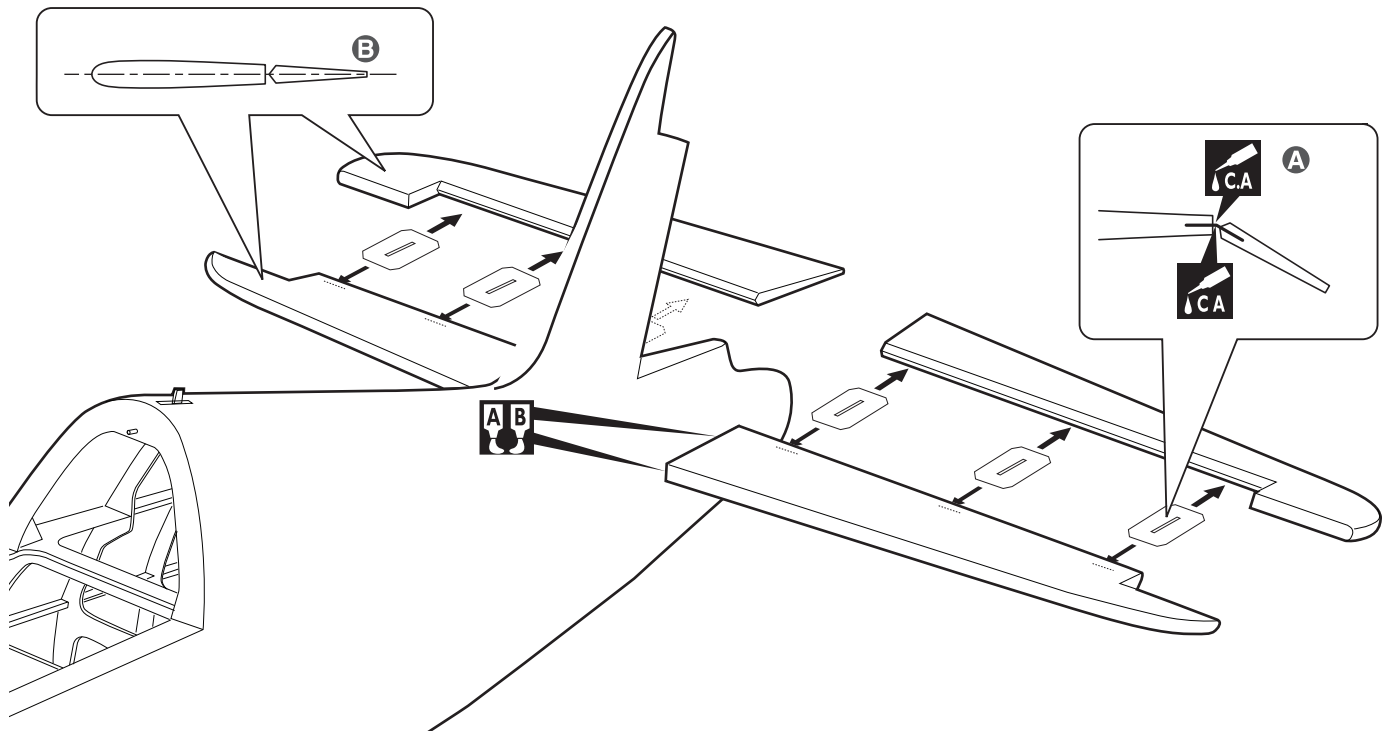
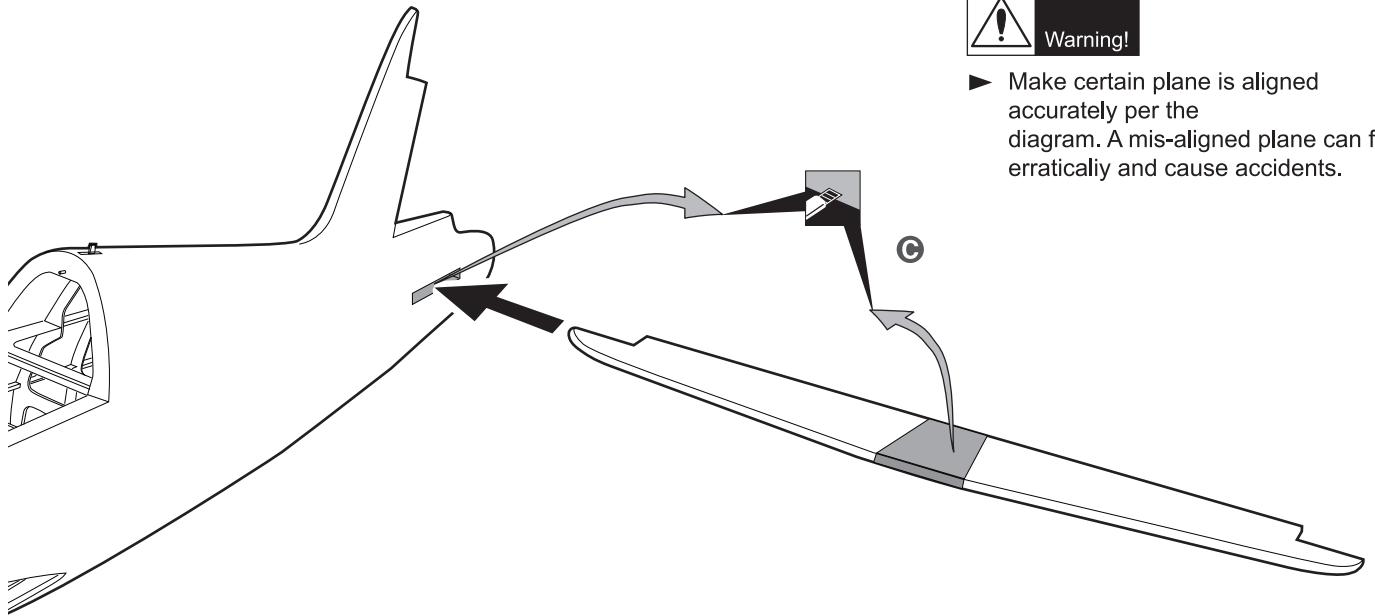

C Cut away film only here

Cut off shaded portion

Apply instant glue (CA glue, super glue).

Apply epoxy glue

A Secure nylon hinges with instant glue, being careful tail wing and elevator.

B Align the center line of horizontal tail with elevator.

INSTALLING RUDDER AND TAIL GEAR

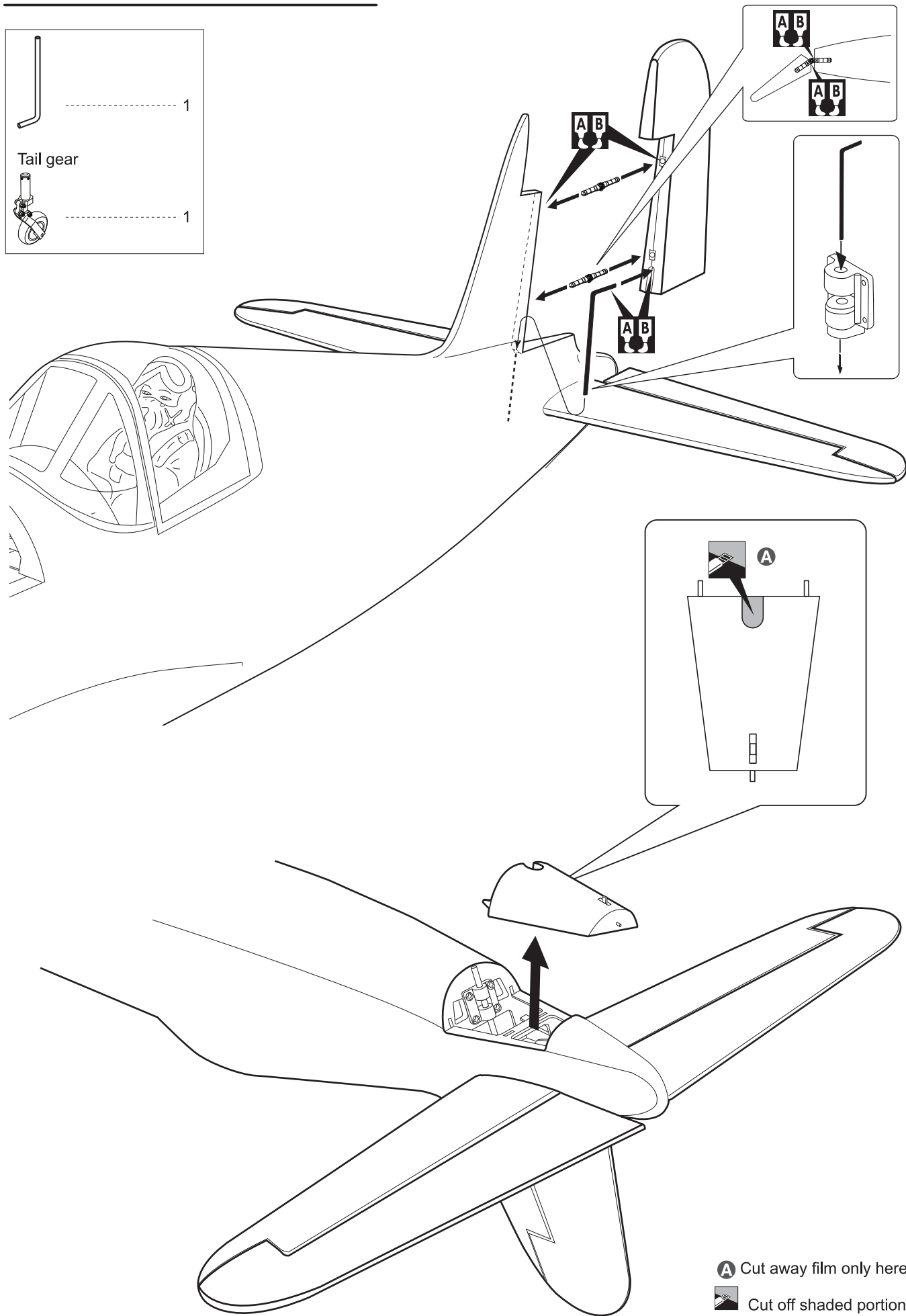
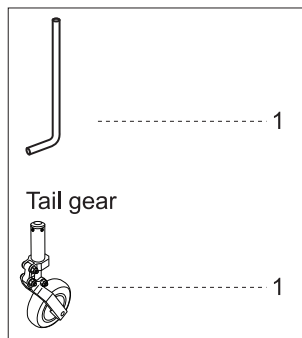

- A Cut away film only here
- Cut off shaded portion
- AB Apply epoxy glue

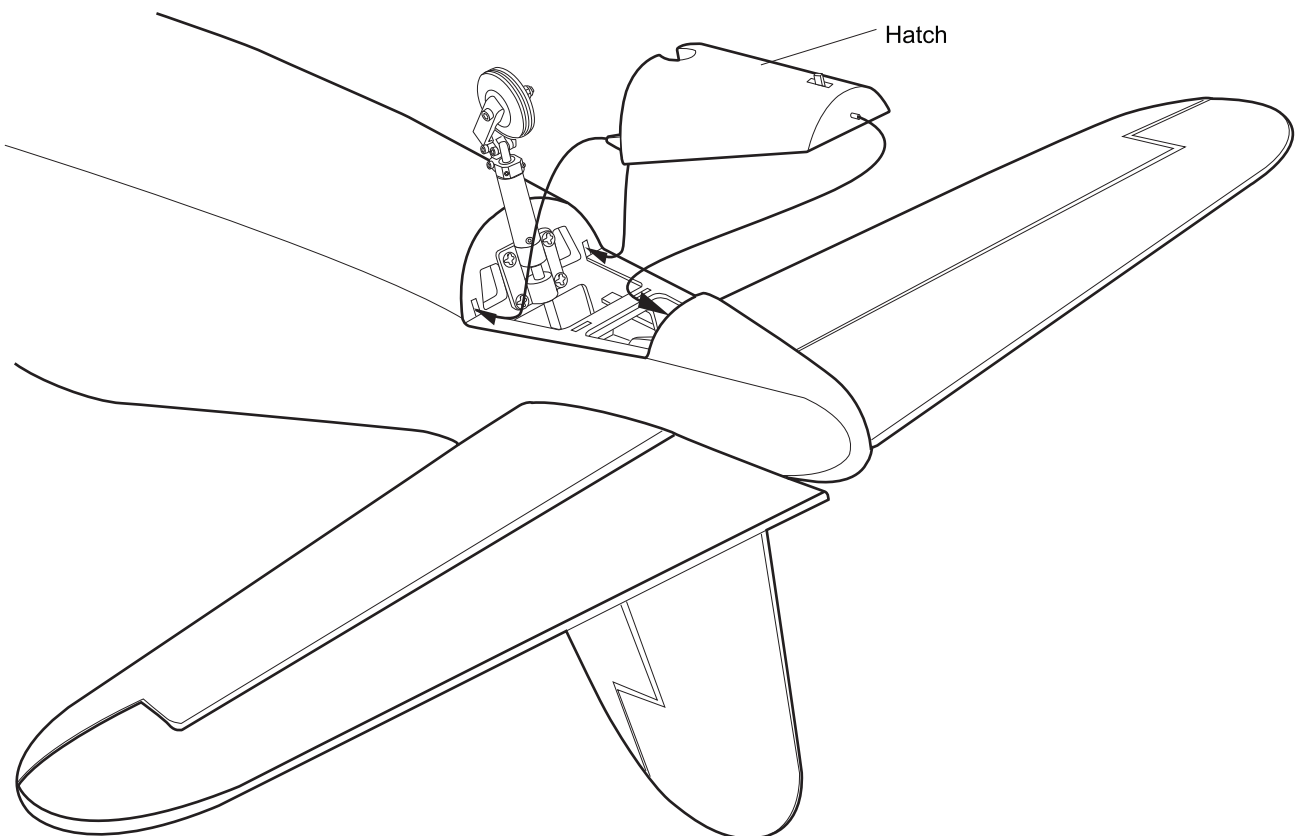
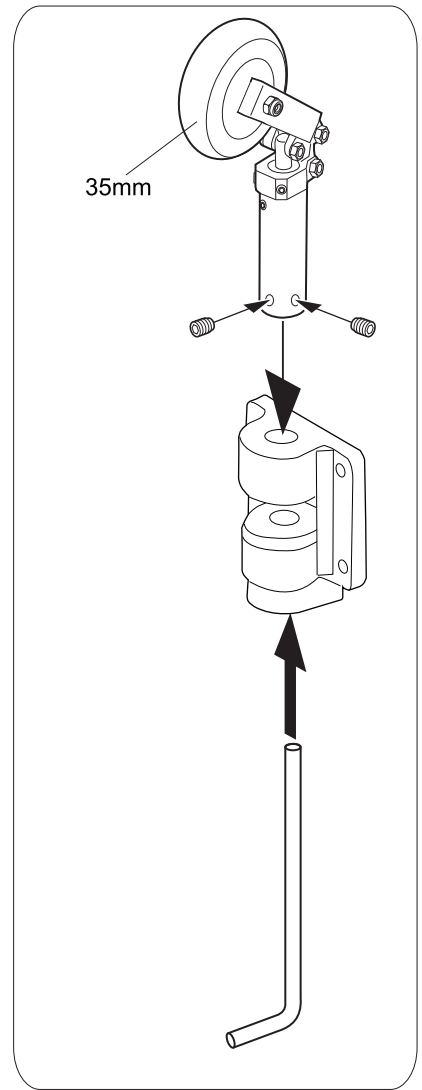
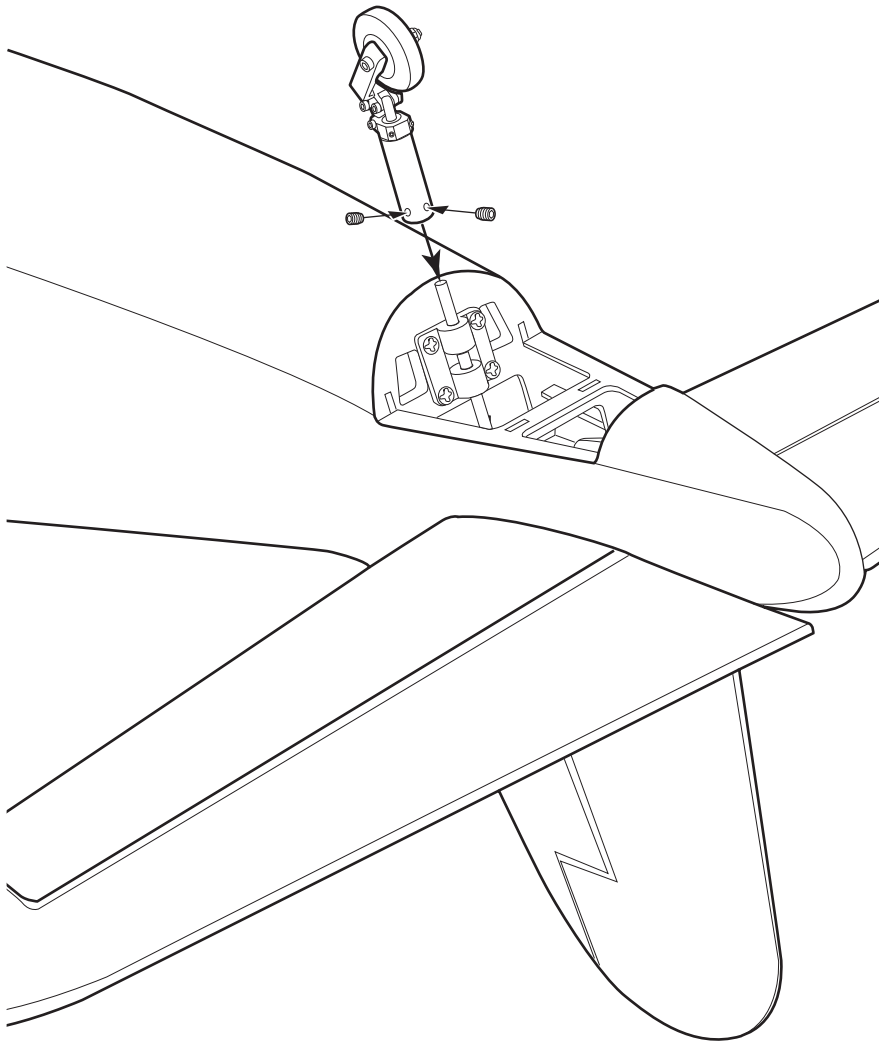

INSTALLING THE RUDDER PUSHROD

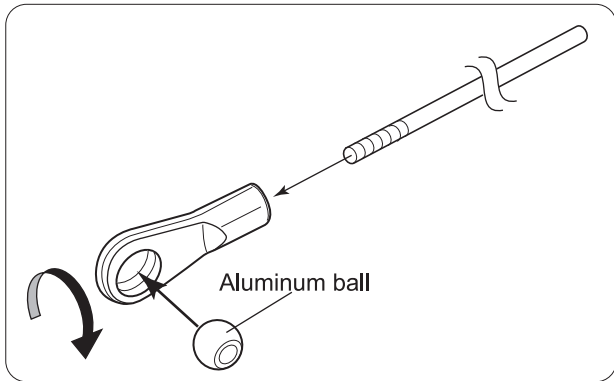

- Snap keeper 1
- 1.7 x 1000mm Push rod 1
- Aluminum ball 2
- 2

- 1
- 3 x 20mm Cap Screw 1
- 2 x 10mm Cap Screw 1

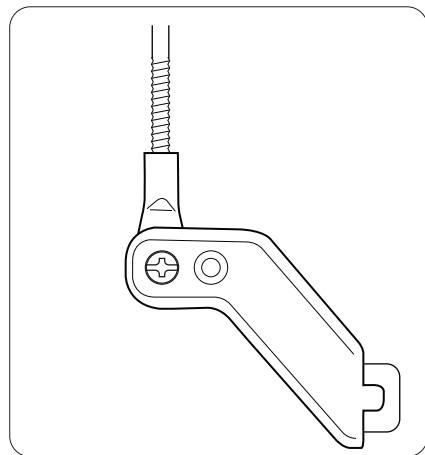
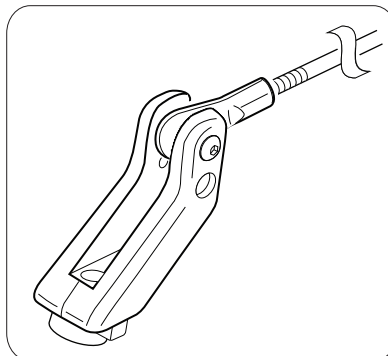
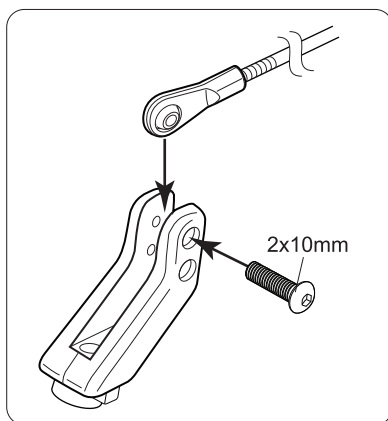
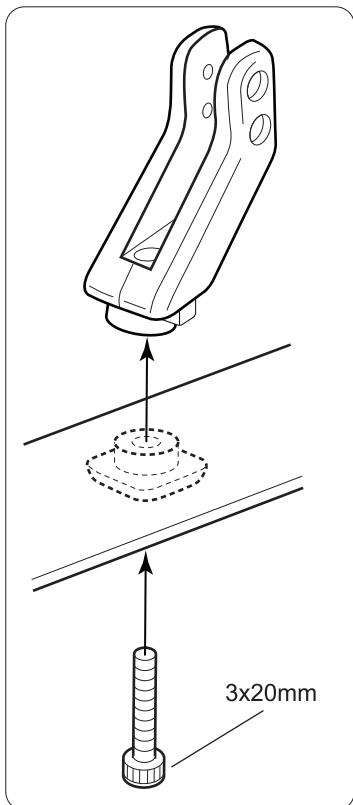
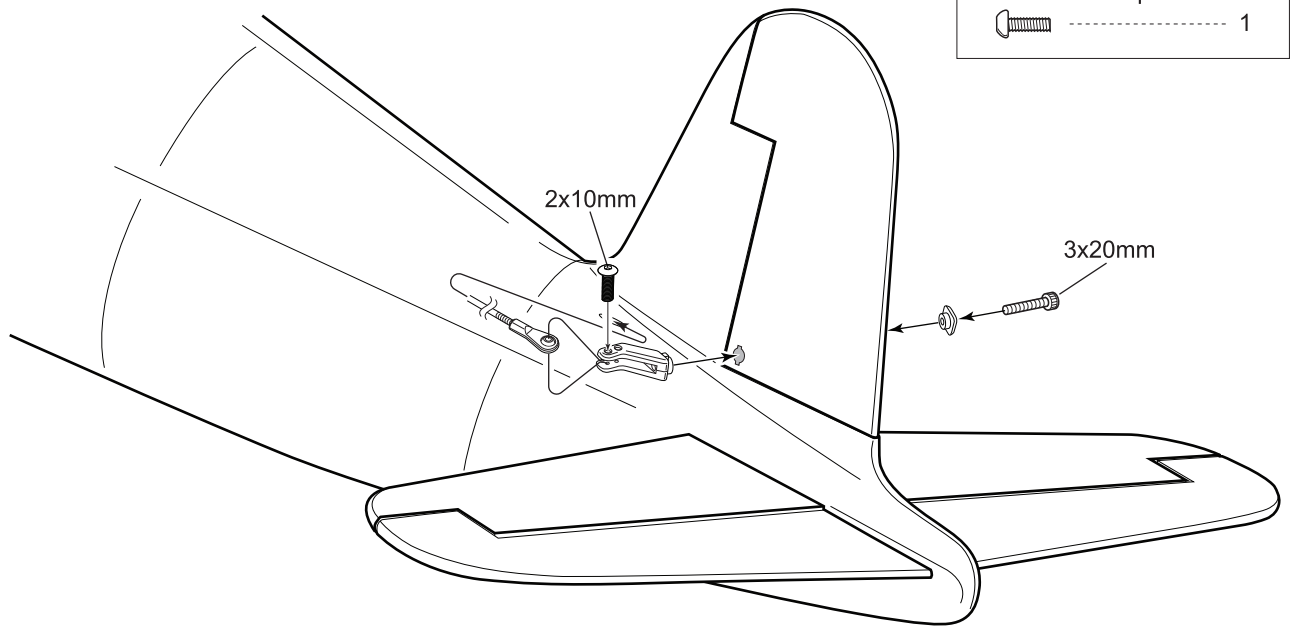

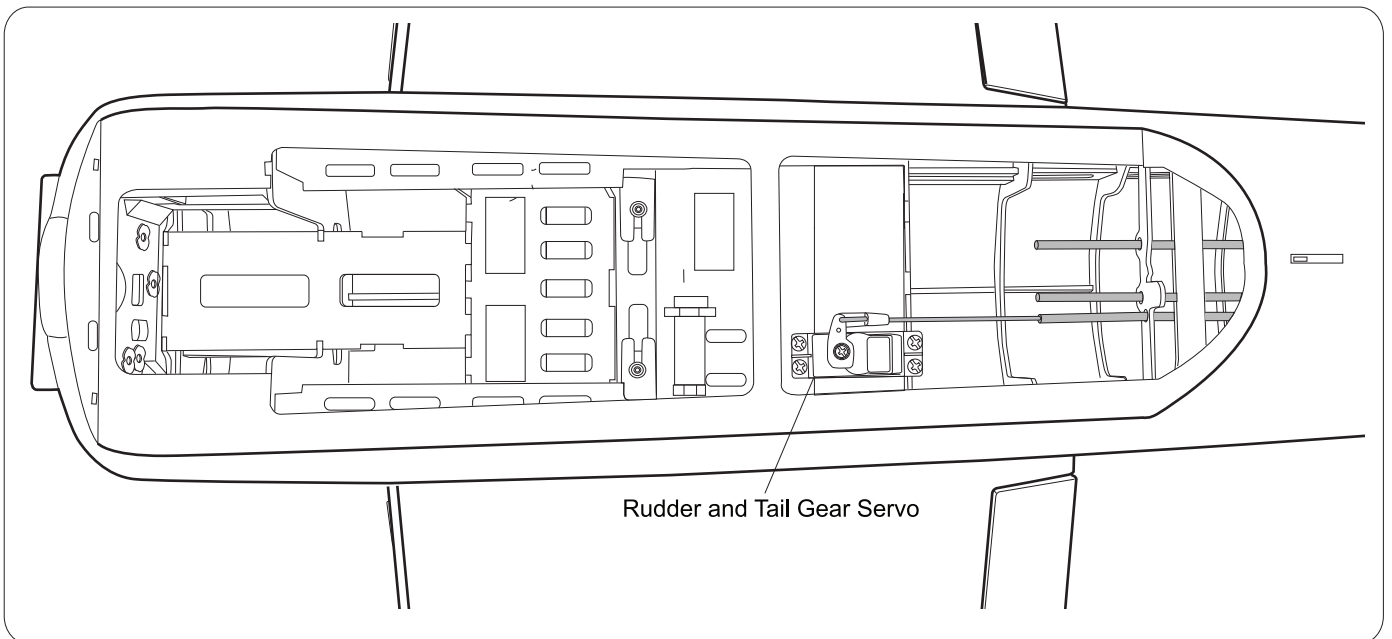
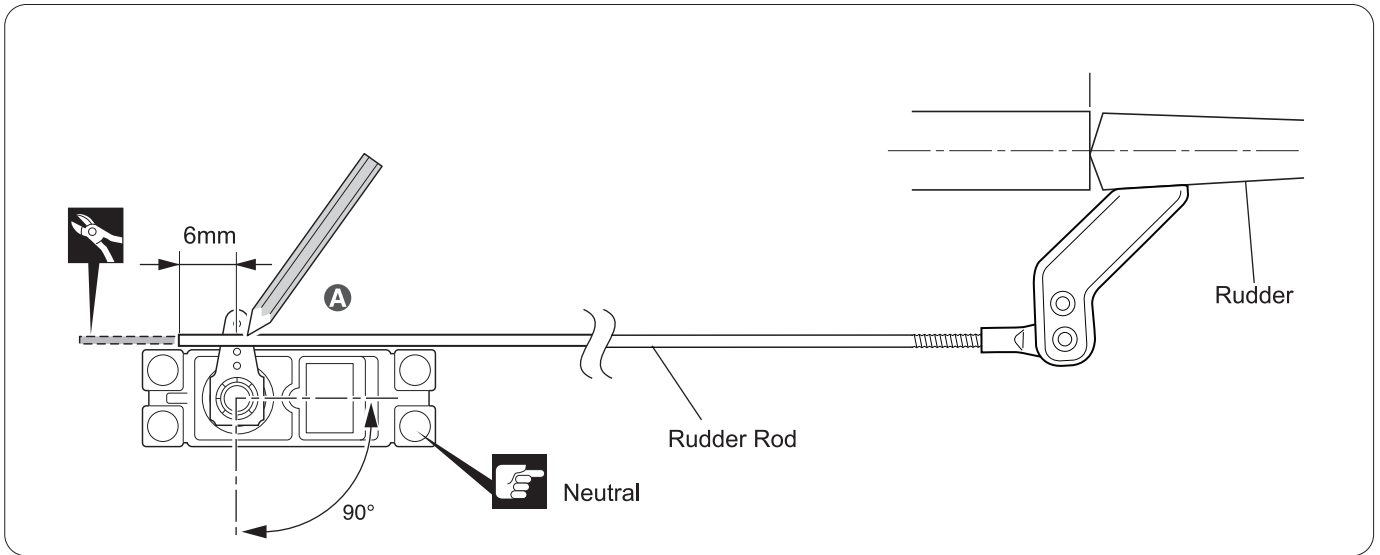
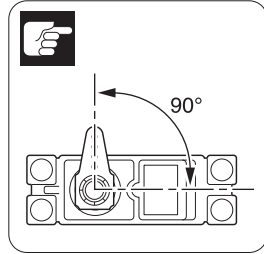
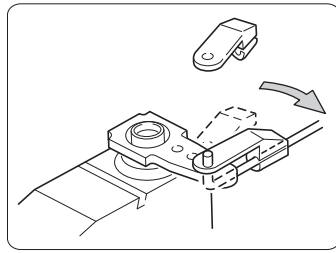
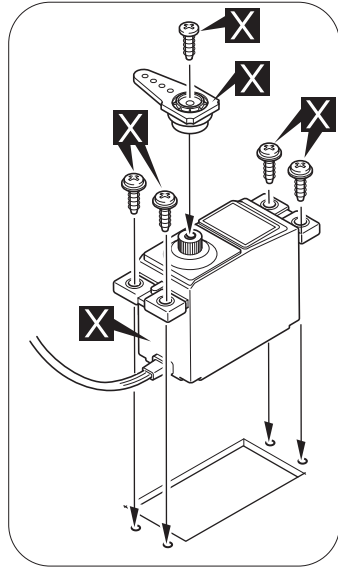
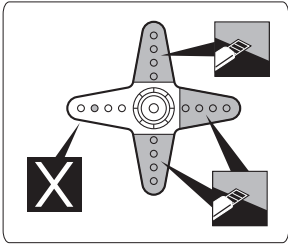







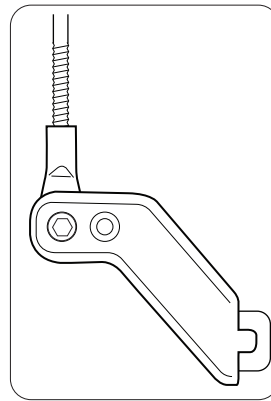
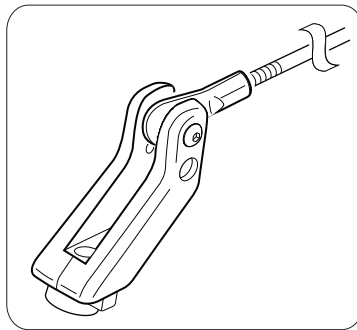
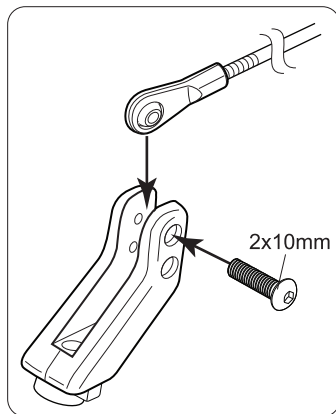
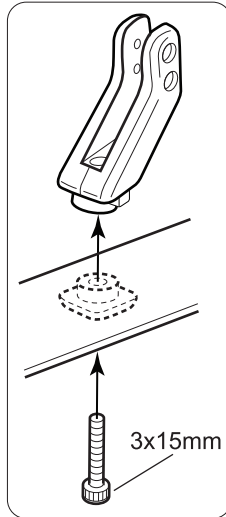
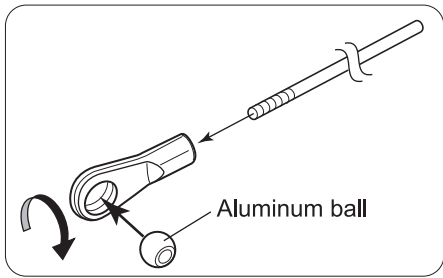

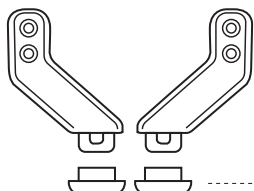
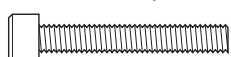
- Cut off shaded portion
- Pay close attention here

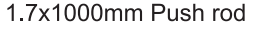

- Cut off excess.
- Must be purchased separately!

INSTALLING THE ELEVATOR PUSHROD



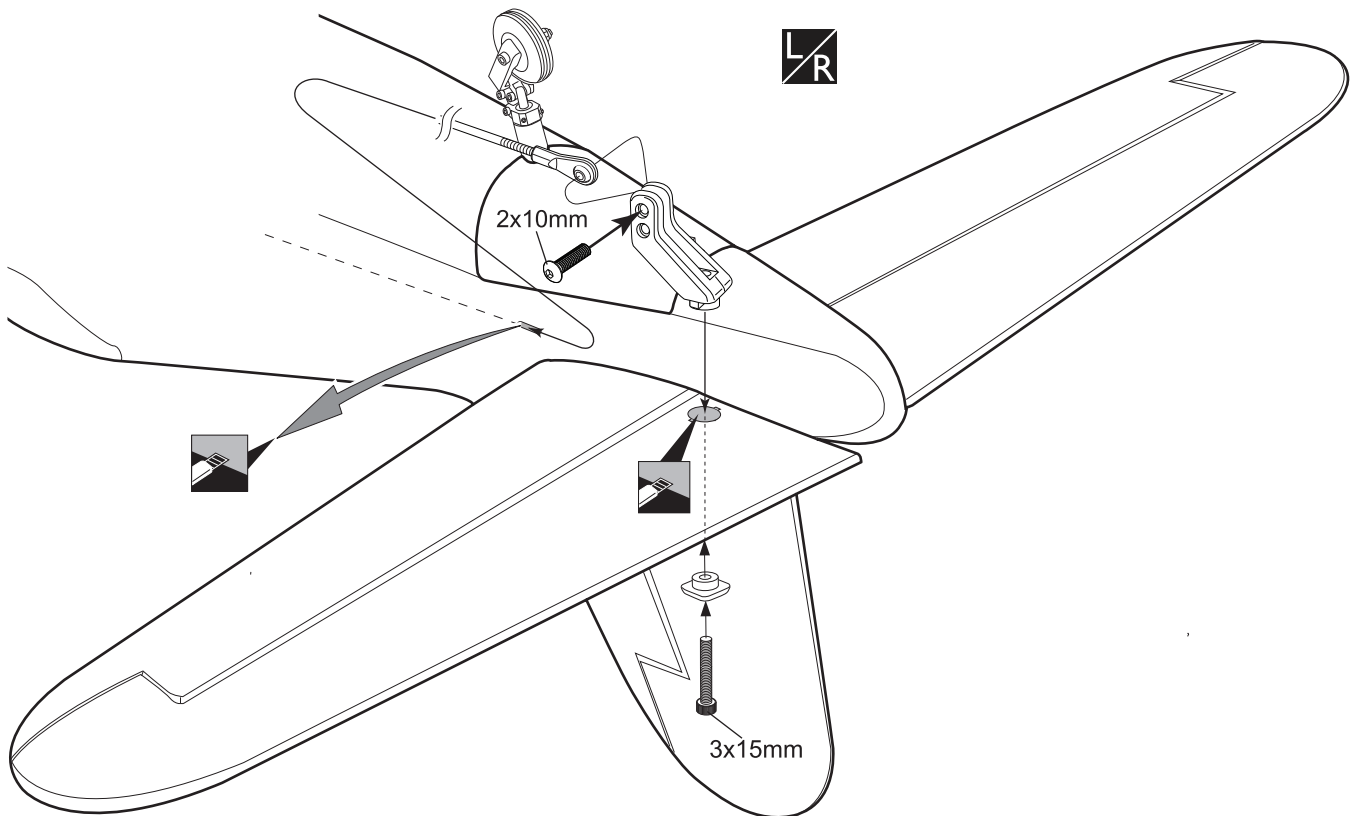

-  1
- 3 x 15mm Cap Screw
-  2
- 2 x 10mm Cap Screw
-  2
- Snap keeper
-  2
- Aluminum ball
-  2
-  2
- 1.7x100mm Push rod
-  1
- 1.7x1000mm Push rod
-  2
- Domino
-  1

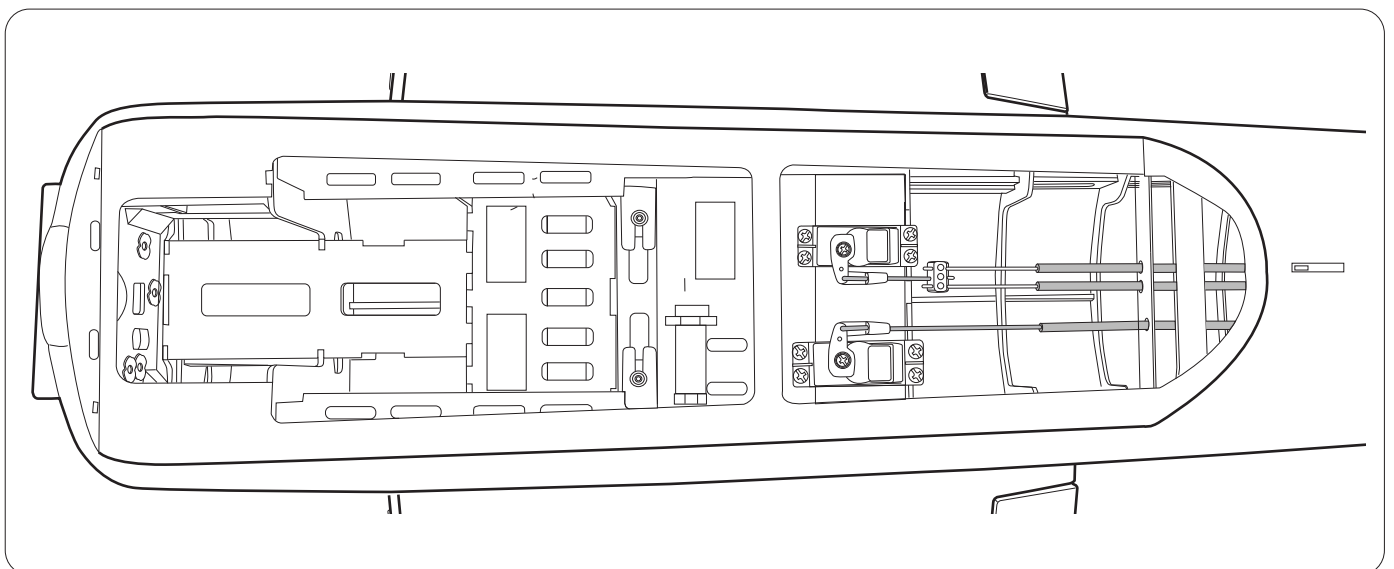
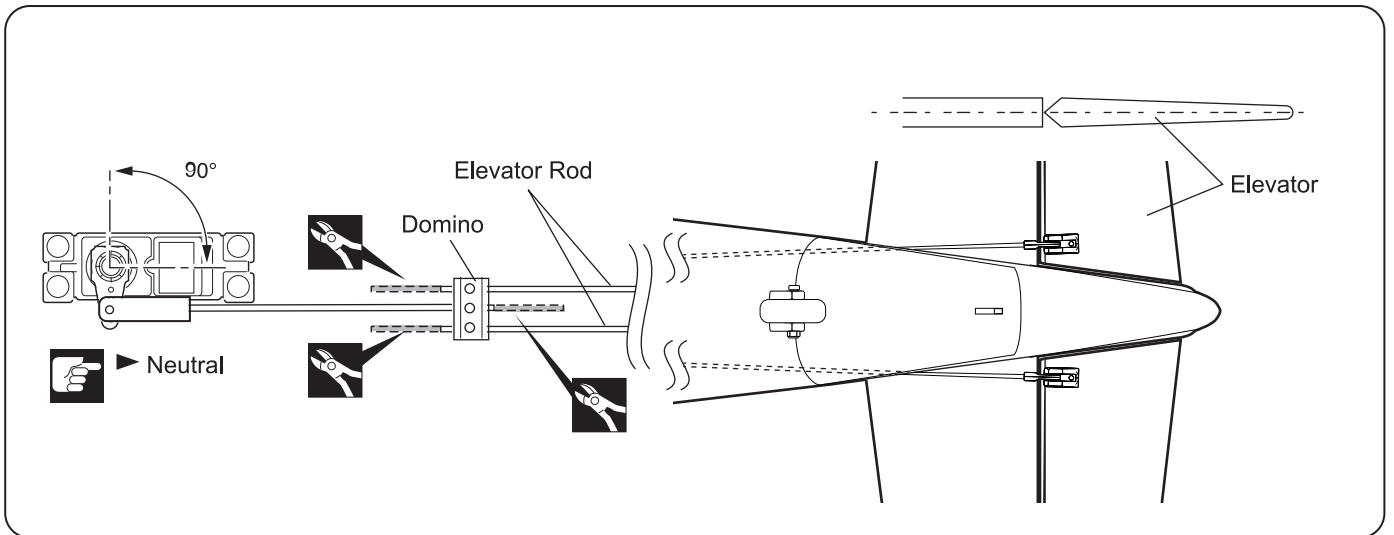
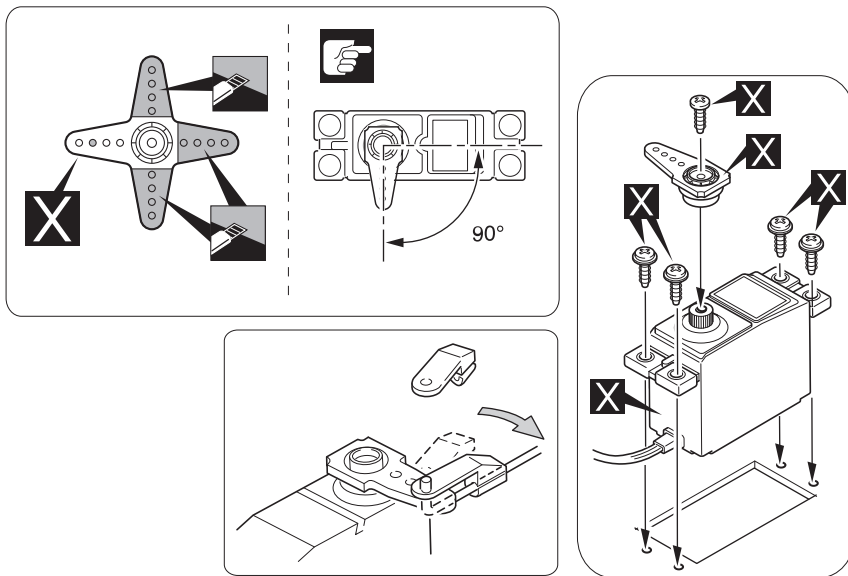

-  Cut off shaded portion
-  Assemble left and right sides the same way.



 Cut off shaded portion

 Apply threadlocker (screw cement).

 Cut off excess.

 Must be purchased separately!

 Pay close attention here

INSTALLING THE ENGINE

Using plate of plywood (supplied with the kit) mark the holes onto the fire wall for installing the engine mount for OS 1.20 or DLE 20CC.

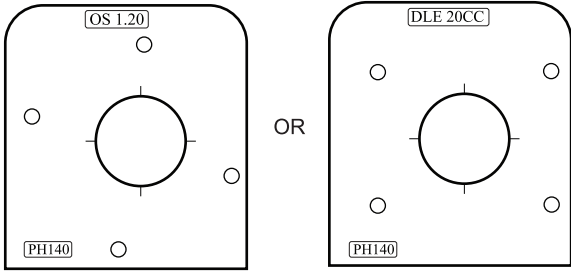

May be you also need to trim some wood from the tri-angle wood for the installation is easy.

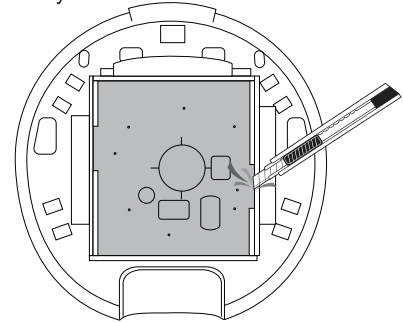

OS 1.20

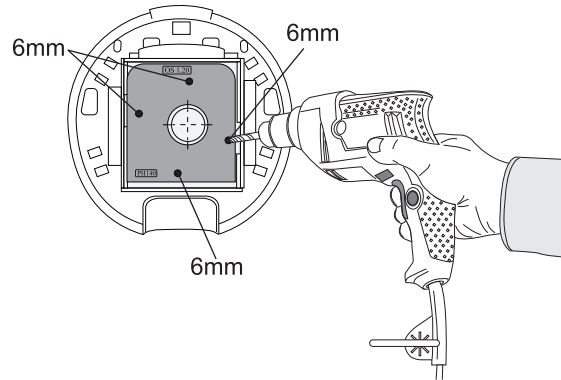
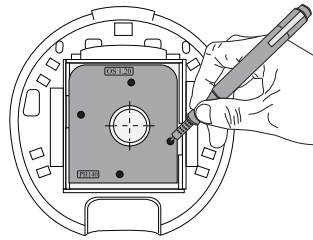
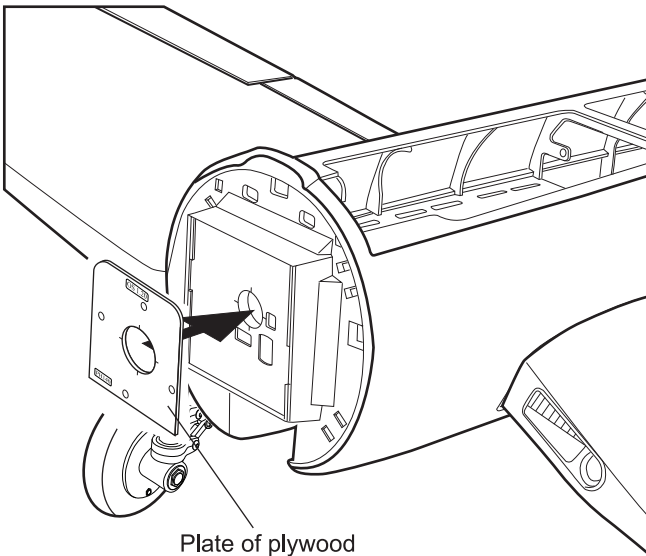

DLE-20CC

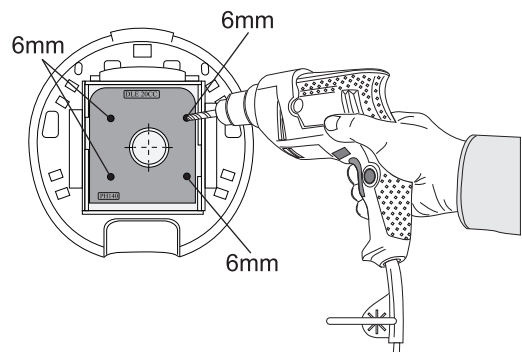
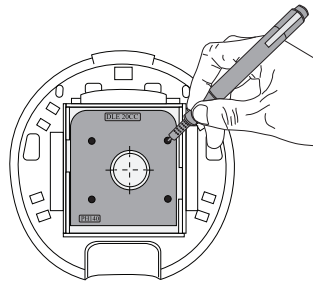
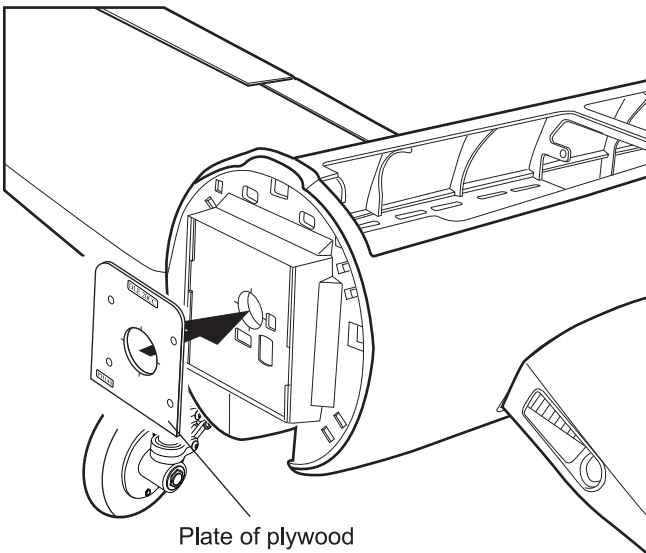

INSTALLING THE ENGINE MOUNT

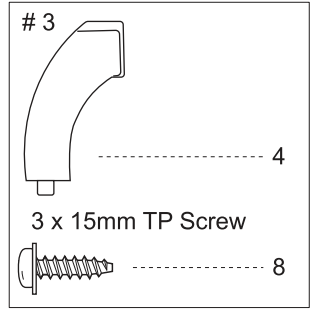
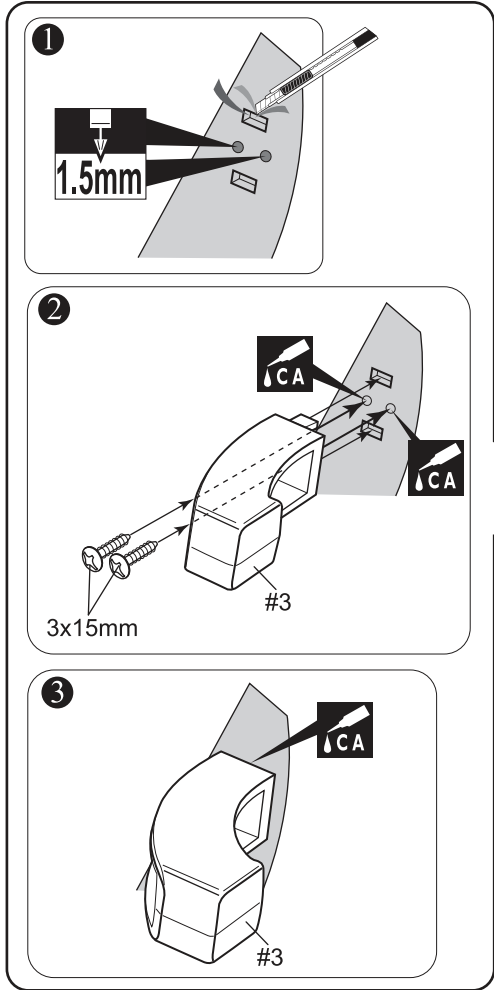

| | |
|--------------------|---|
| 4 x 30mm Cap Screw | 4 |
| 4mm Washer | 4 |
| 4mm Spring Washer | 4 |
| 4mm Mount Nut | 4 |

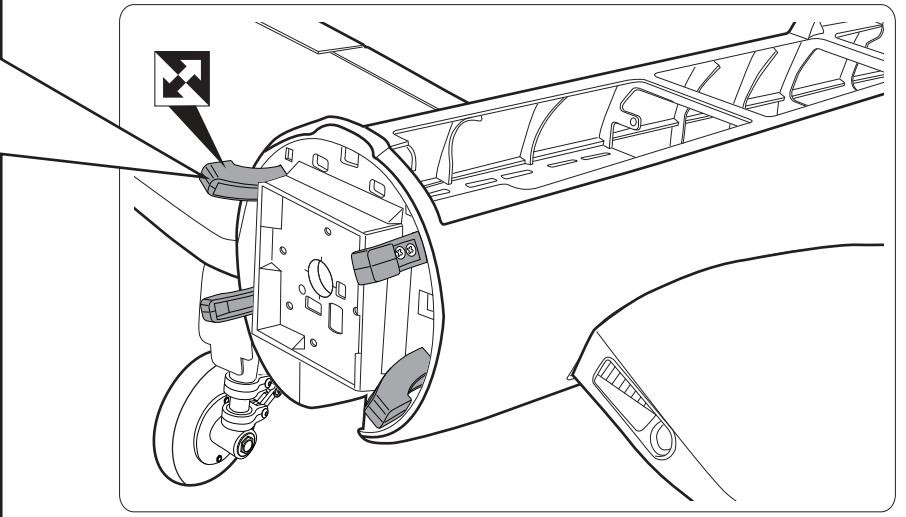

- Apply instant glue (CA glue, super glue).
- Note the direction.
- Drill holes with the specified diameter.

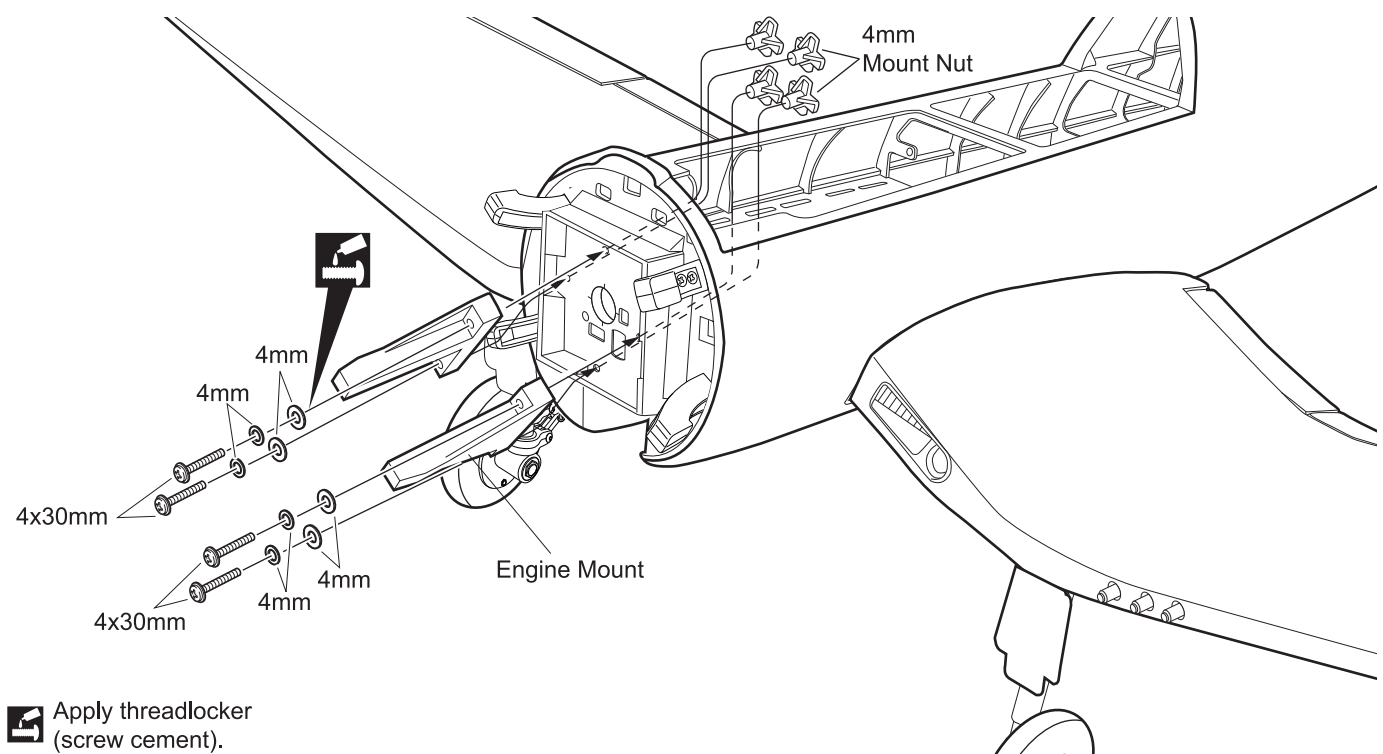

- Apply threadlocker (screw cement).

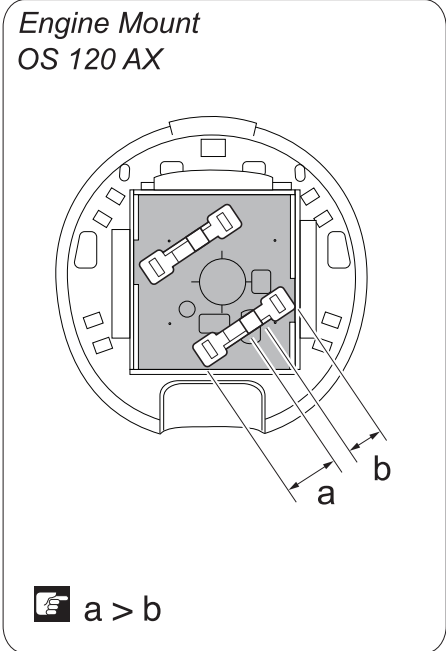
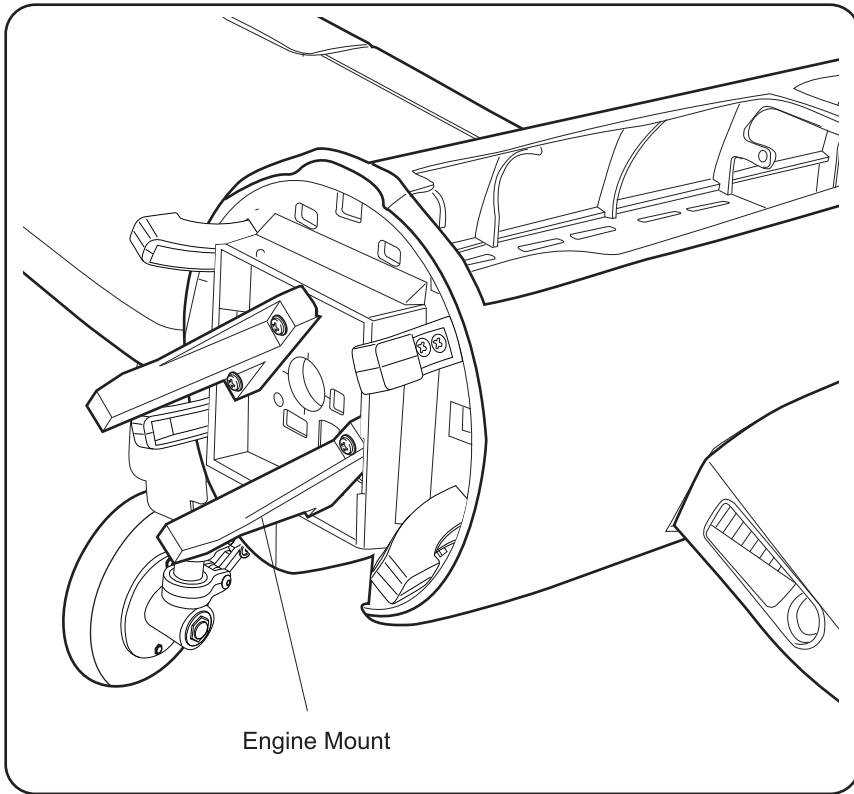

INSTALLING THE FUEL TANK

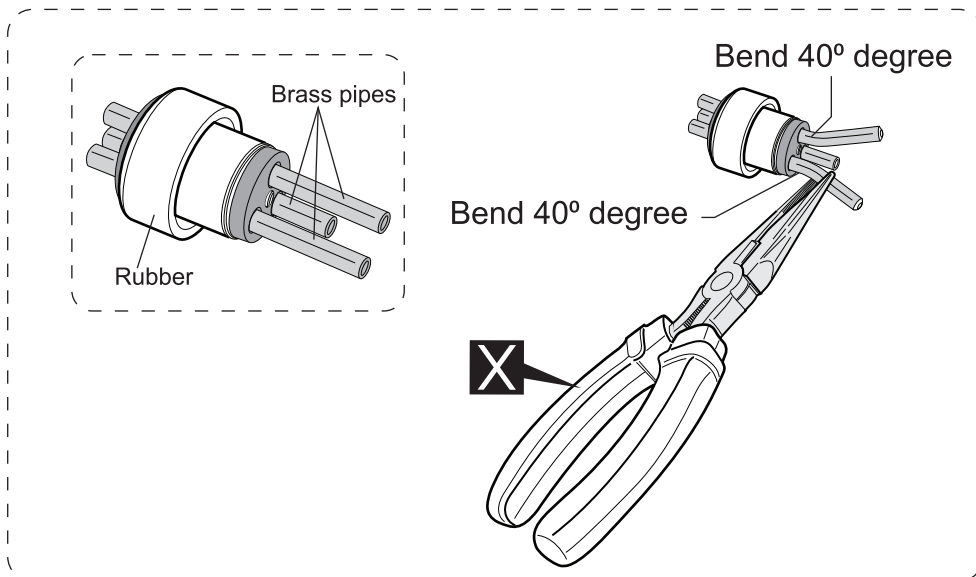
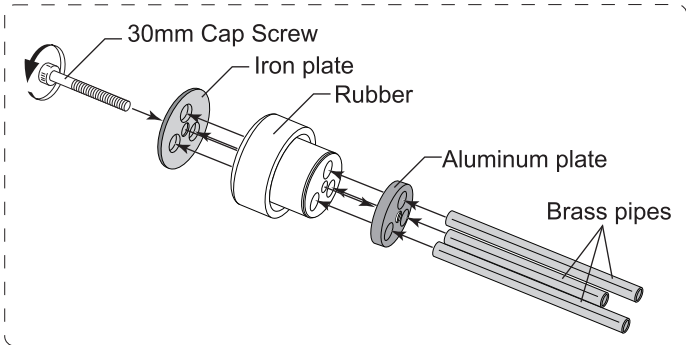

- | | | |
|----------------|-------|---|
| #6 Fuel Tank | | 1 |
| Rubber | | 1 |
| Zip tie | | 4 |
| Foam ring | | 2 |
| Iron plate | | 1 |
| Aluminum plate | | 1 |
| Clunks | | 1 |
| Brass pipes | | 2 |
| 30mm Screw | | 1 |

X Must be purchased separately!

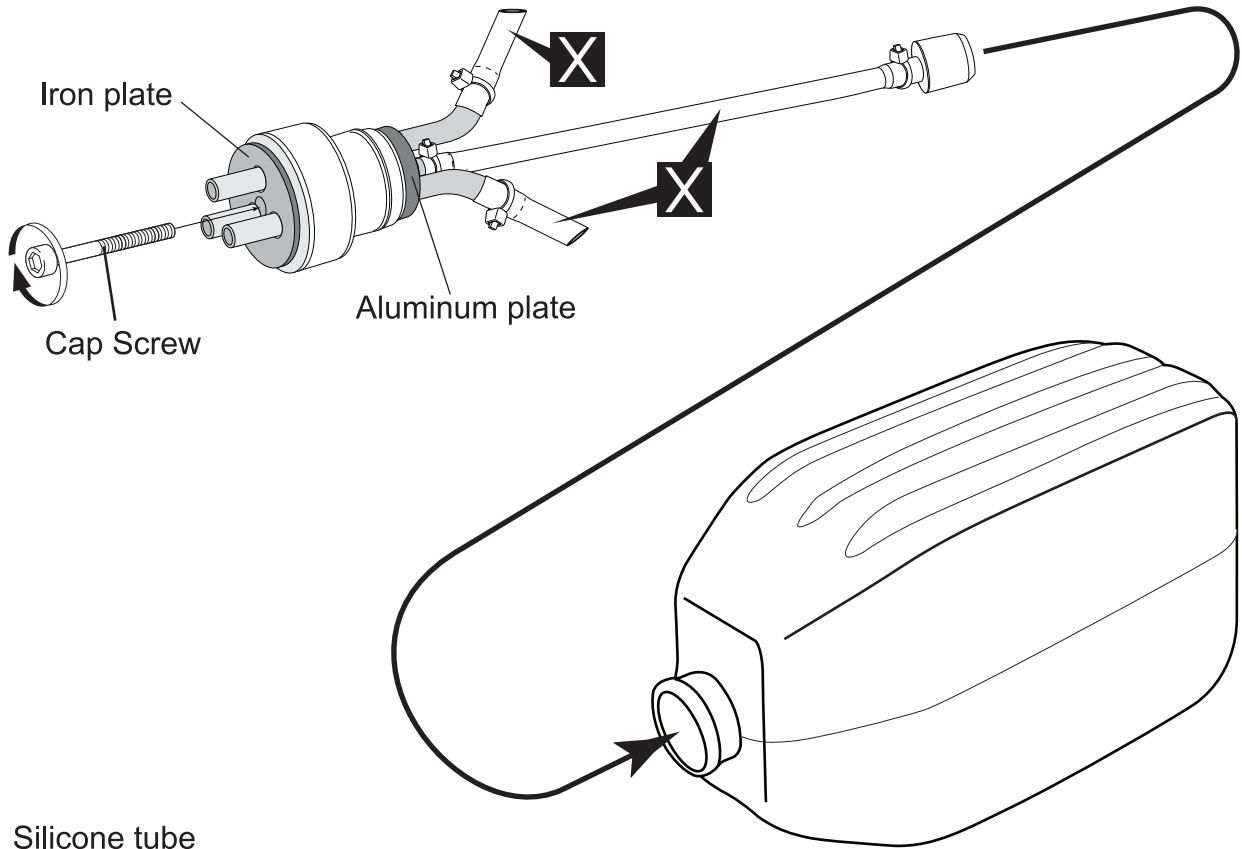

X Silicone tube
(Must be purchased separately!)

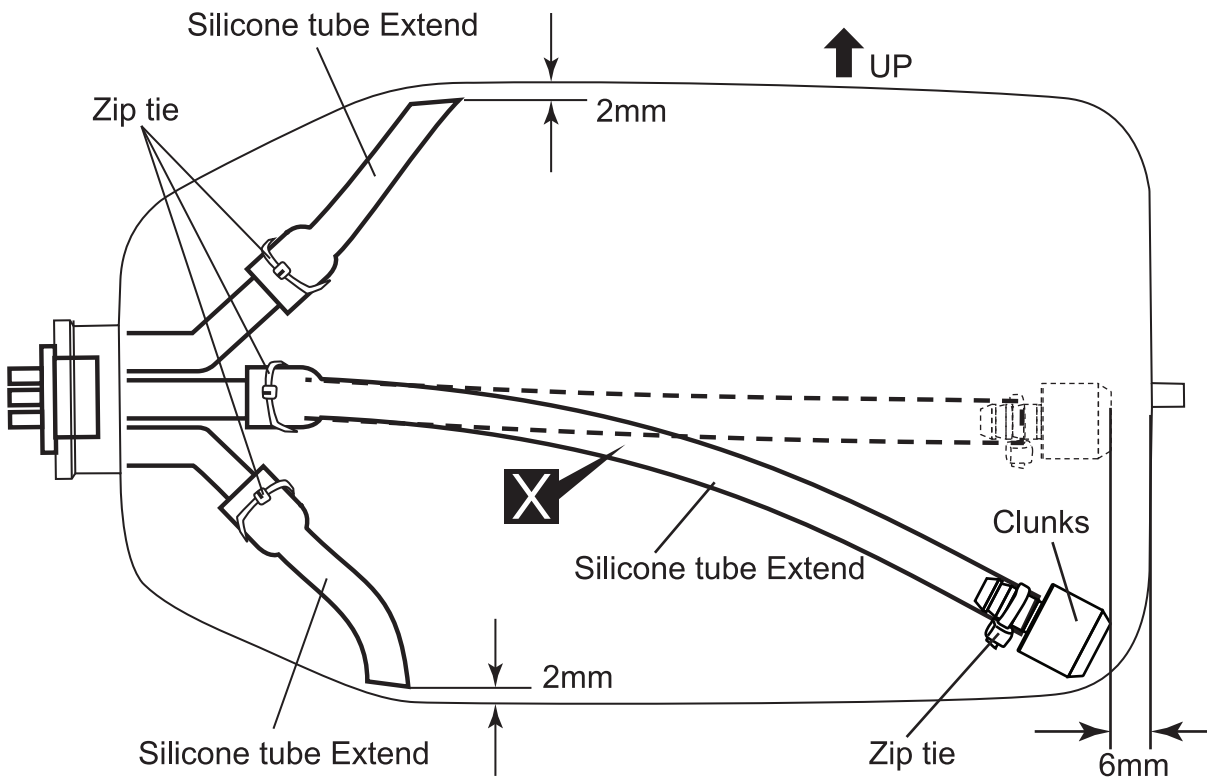

A < B

X Must be purchased separately!

6

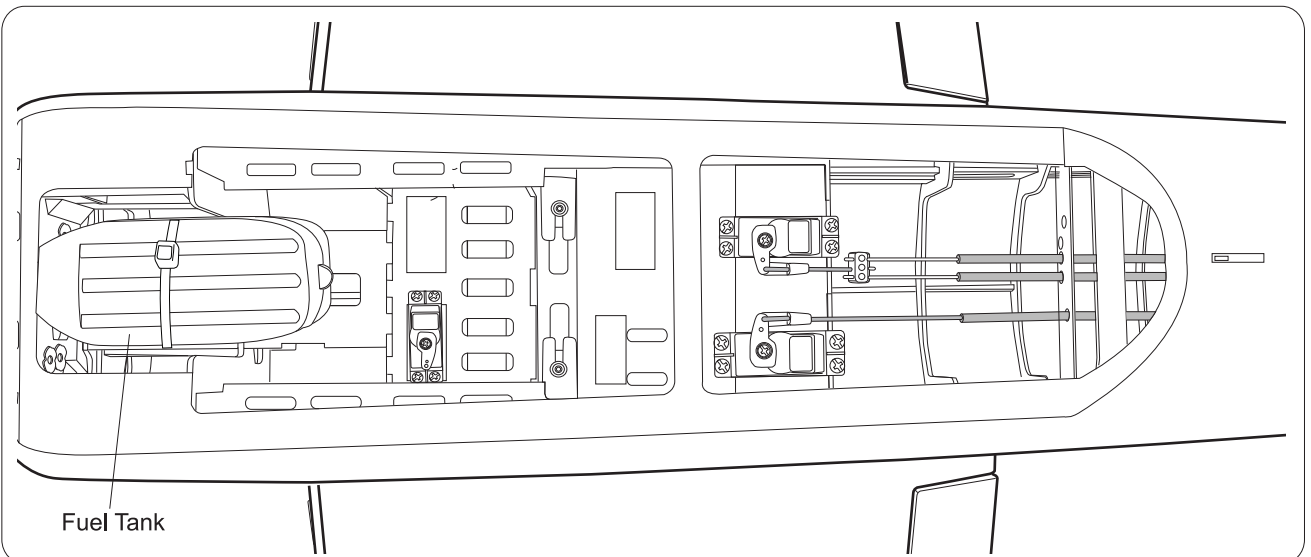
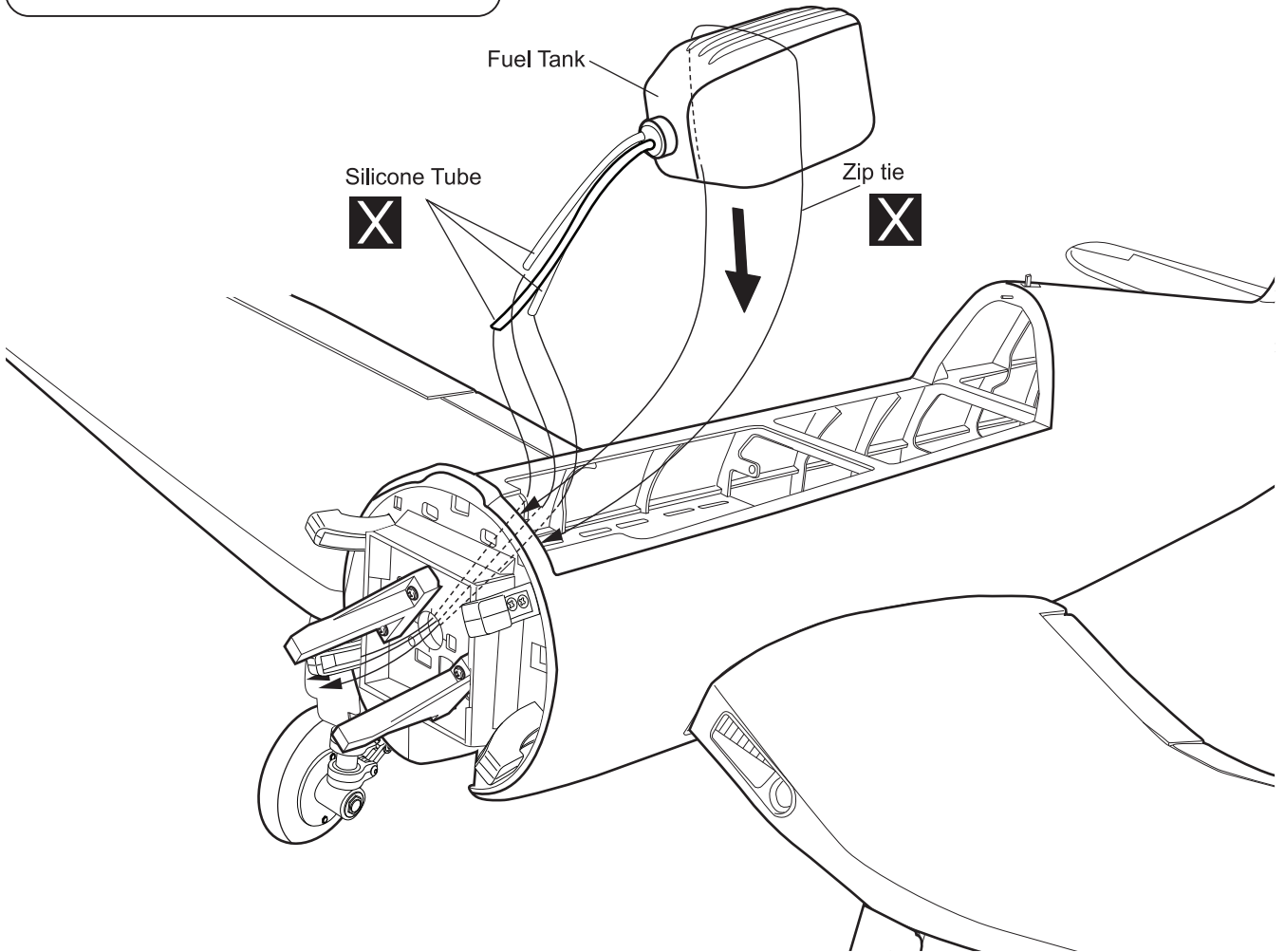
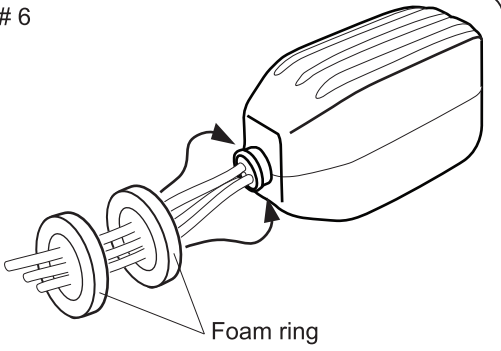

INSTALLING THE THROTTLE PUSHROD SERVO

1. Place the engine into the engine mount and align it properly with the front of the cowling.

! *If your engine is equipped with a remote needle valve, we suggest installing it into the engine at this time.*

2. Slide the pushrod housing through the hole in the firewall, through the hole in the forward bulkhead, and into the servo compartment.

3. Apply epoxy glue to the pushrod housing where it exits the firewall and where it passes through the forward bulkhead. This will secure the housing in place.
4. Using a modeling knife, cut off the nylon pushrod housing 26mm in front of the servo tray.
3. Apply epoxy glue to the pushrod housing where it exits the firewall and where it passes through the forward bulkhead. This will secure the housing in place.

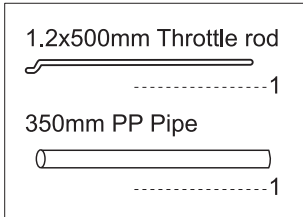

► *Temporarily install the engine and make a hole for the throttle rod by aligning with the position of the throttle lever*

AB Apply epoxy glue

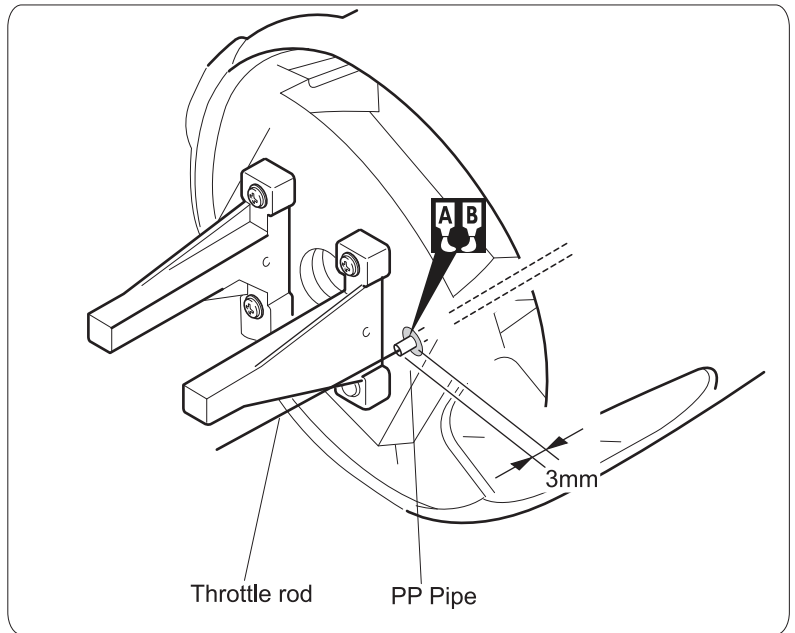

INSTALLING THE ENGINE

Locate the long piece of wire used for the throttle pushrod. One end of the wire has been pre-bend in to a "Z" bend at the factory. This "Z" bend should be inserted into the throttle arm of the engine when the engine is fitted onto the engine mount. Fit the engine to the engine mount using the screws provided.

OS 120 AX

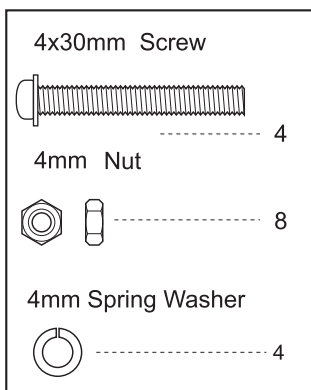

X Must be purchased separately!

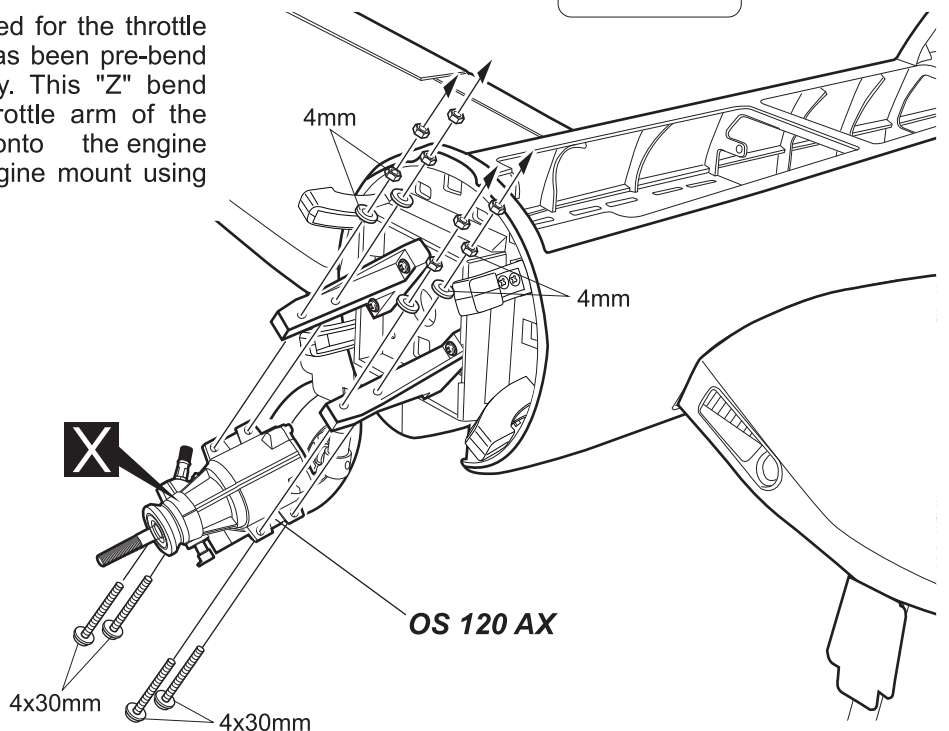

OS 120 AX

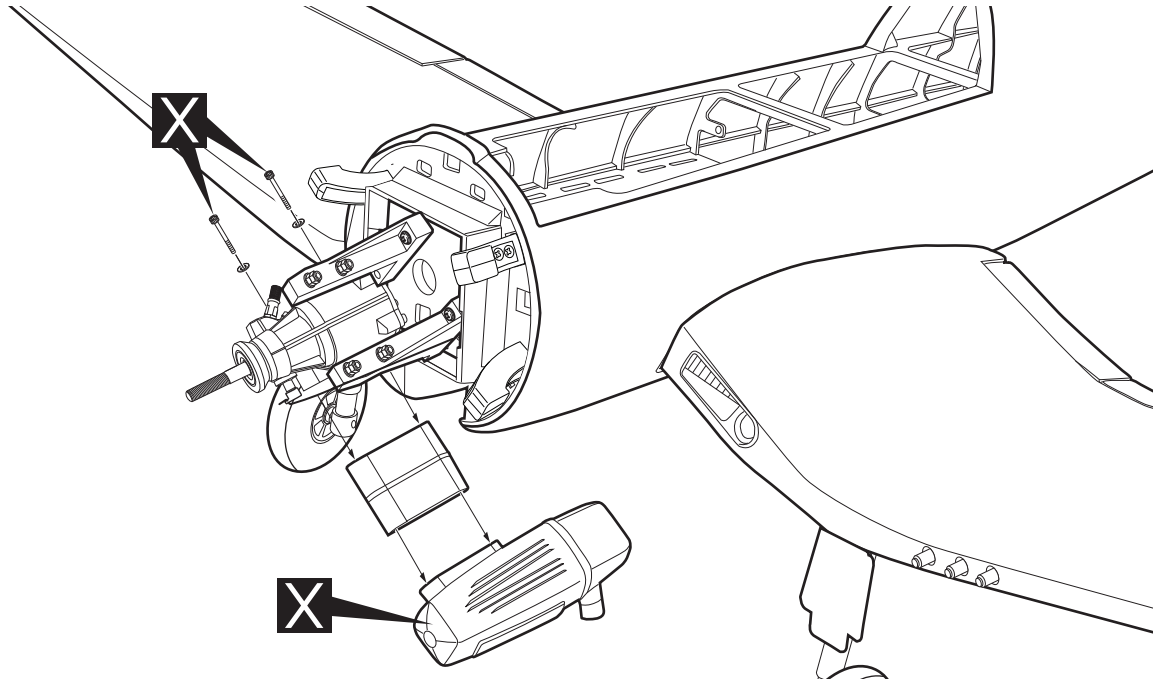

OS 120 AX

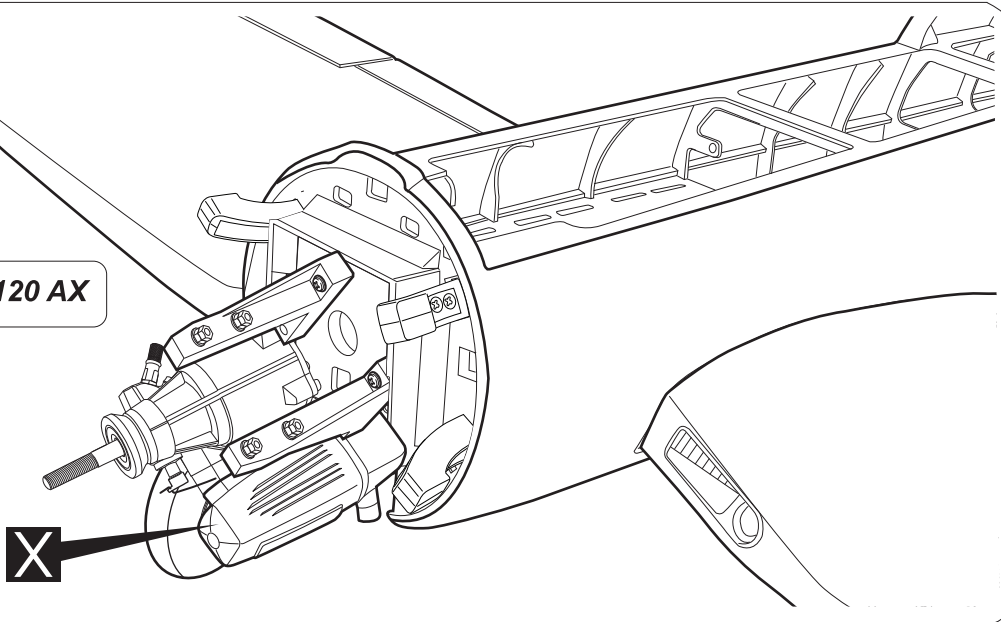

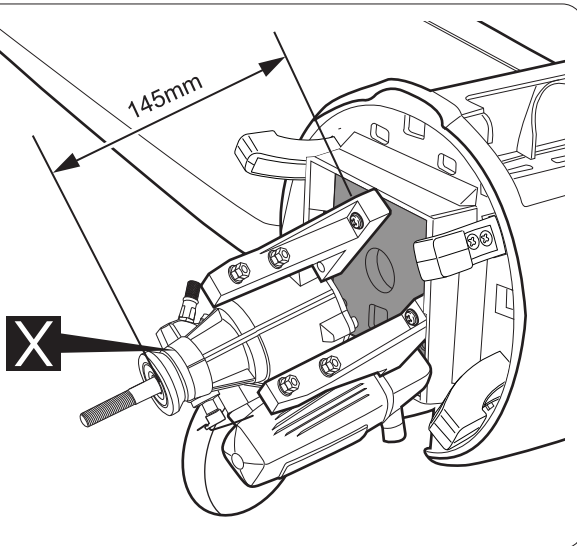

145mm



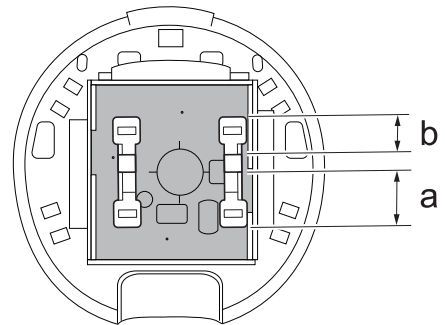

Engine Mount
DLE 20

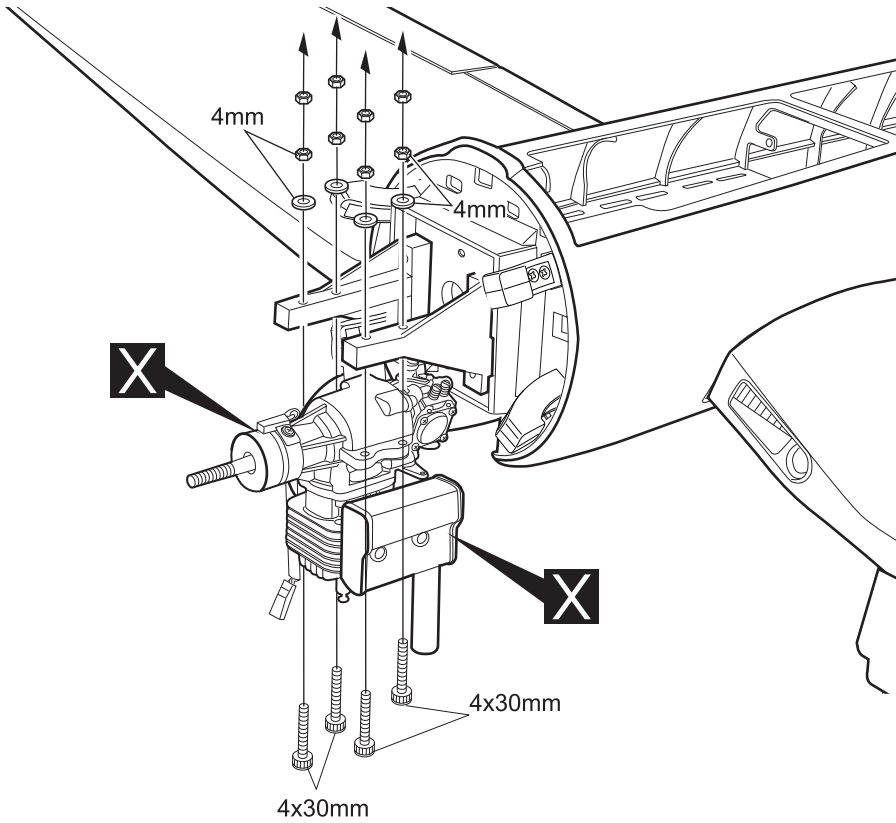

 $a > b$

 Must be purchased separately!

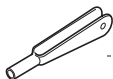

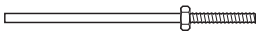
- Metal kwik link (M2)  2
- Silicone  2
- 1.7x600mm Push rod  2

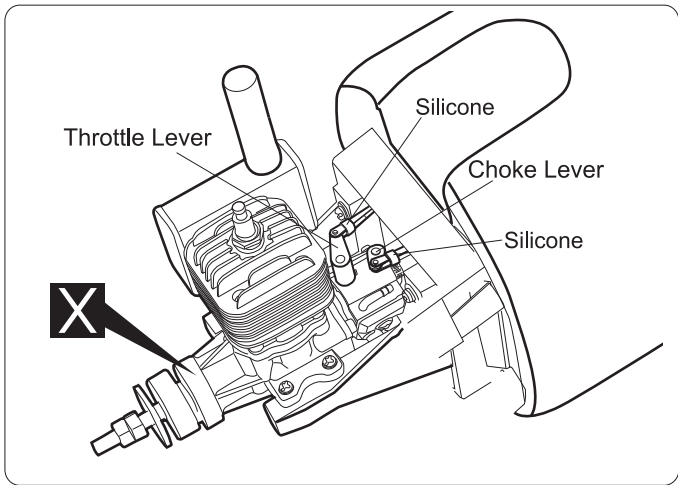
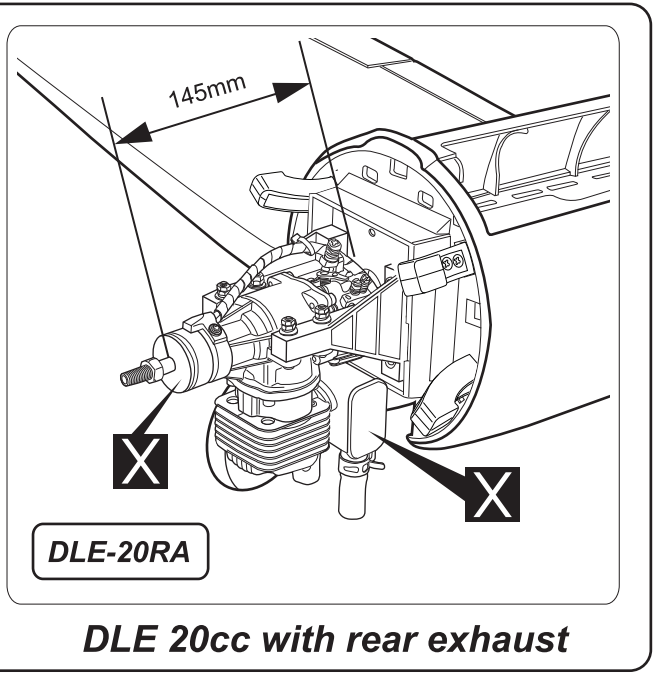
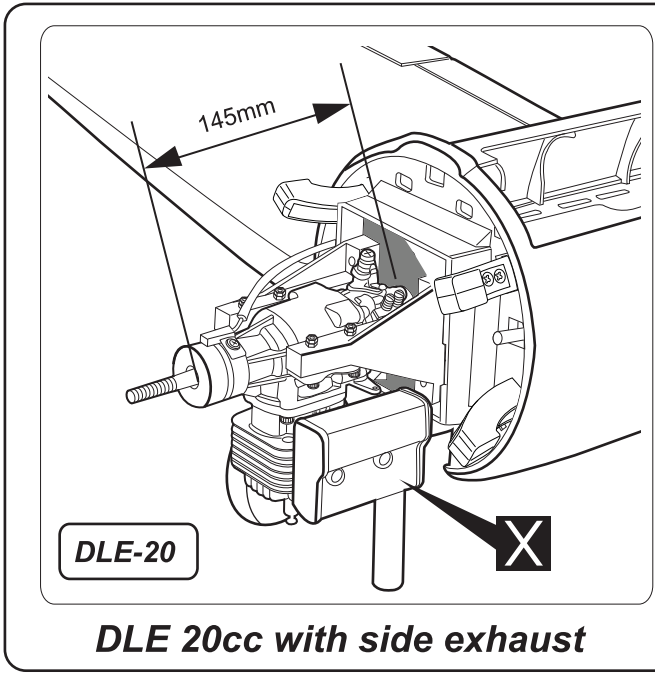
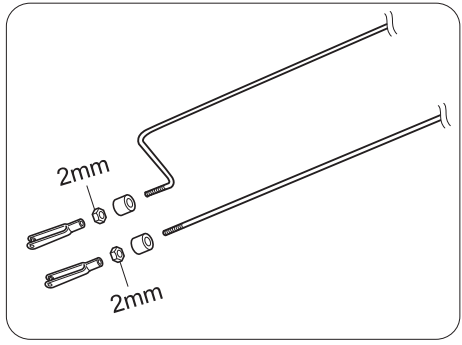

X Must be purchased separately!

INSTALLING THE THROTTLE

1. Install one adjustable metal connector through the third hole out from the center of one servo arm, enlarge the hole in the servo arm using a 2mm drill bit to accommodate the servo connector. Remove the excess material from the arm.

! After installing the adjustable metal connector apply a small drop of thin C/A to the bottom nut. This will prevent the connector from loosening during flight.

2. Plug the throttle servo into the receiver and turn on the radio system. Check to ensure that the throttle servo output shaft is moving in the correct direction. When the throttle stick is moved forward from idle to full throttle, the throttle barrel should also open and close using this motion. If not, reverse the direction of the servo, using the transmitter.

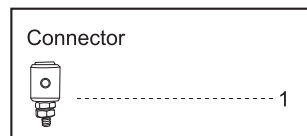

3. Slide the adjustable metal connector / servo arm assembly over the plain end of the pushrod wire. Position the throttle stick and the throttle trim at their lowest positions.
4. Manually push the carburetor barrel fully closed. Angle the arm back about 45 degree from center and attach the servo arm onto the servo. With the carburetor barrel fully closed, tighten the set screw in the adjustable metal connector.
5. Remove the excess throttle pushrod wire using wire cutters and install the servo arm retaining screw.

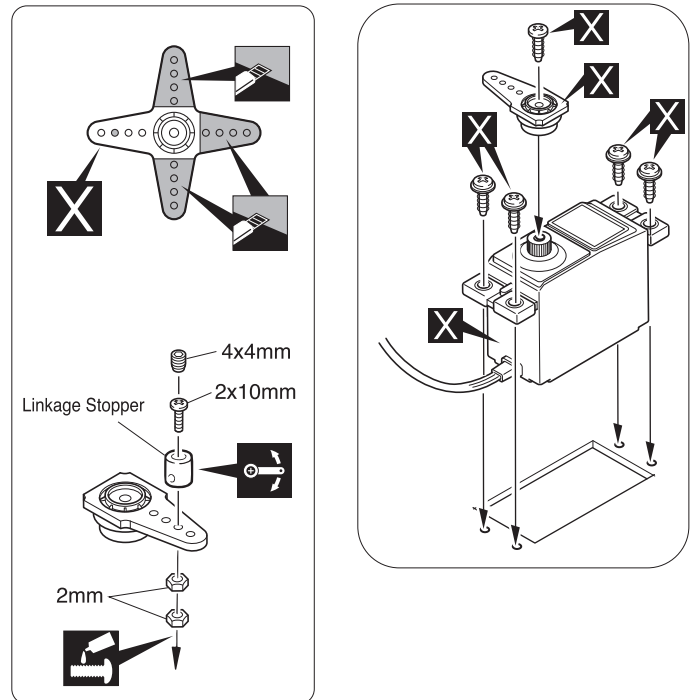

OS 120 AX

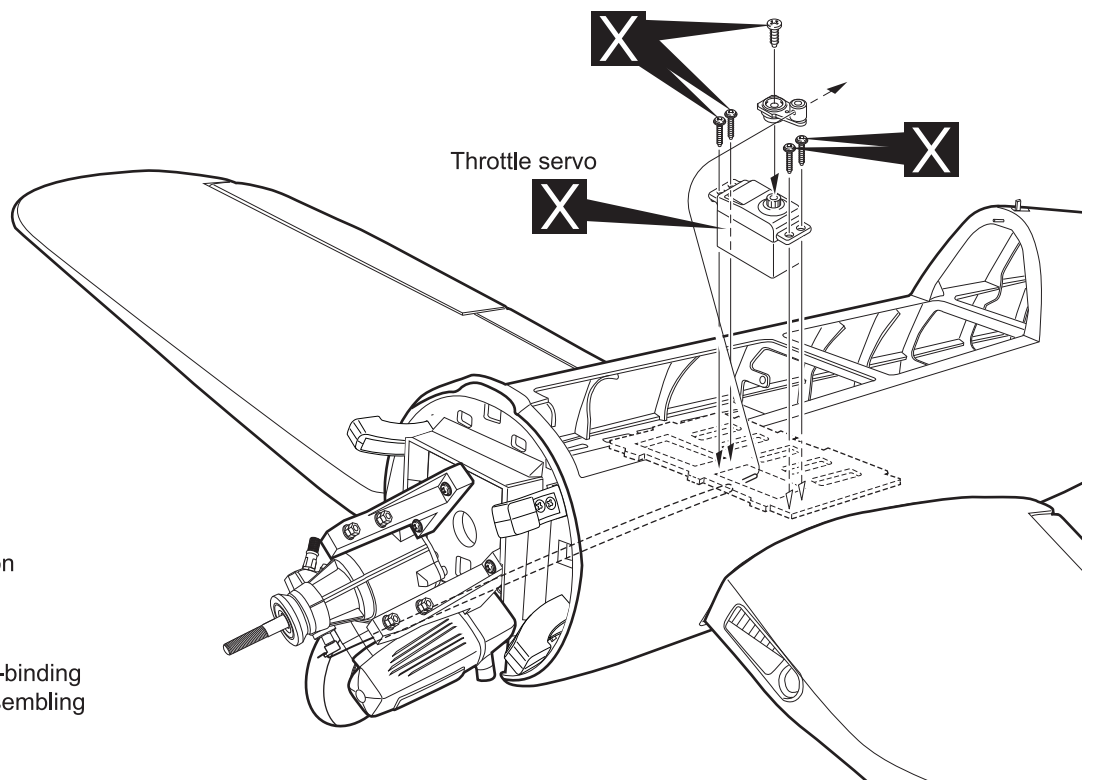

- Cut off shaded portion
- Must be purchased separately!
- Ensure smooth, non-binding movement when assembling
- Apply threadlocker (screw cement).

OS 120 AX

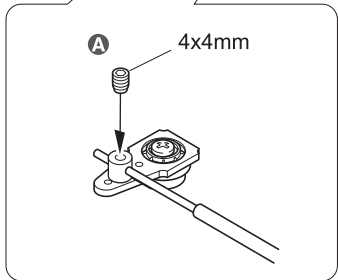
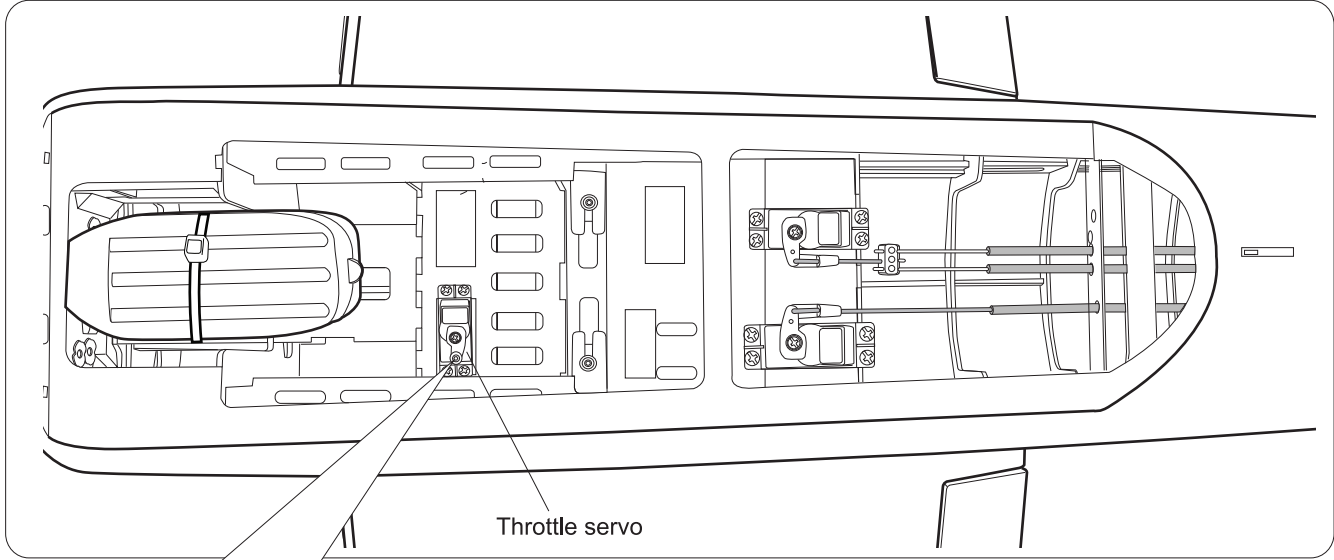
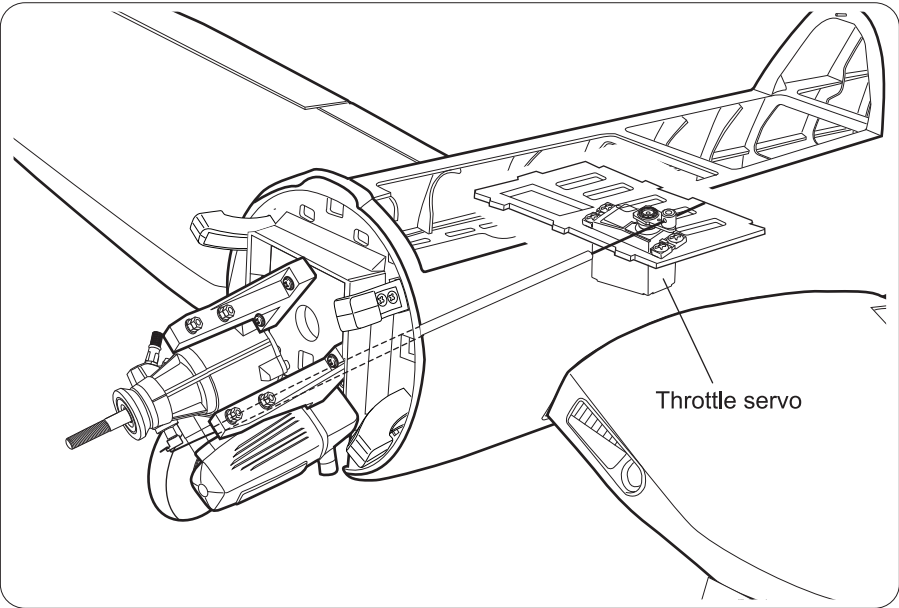

A Adjust the throttle input (transmitter throttle stick), throttle trim movement and the carburettor opening to the suitable position and screw in the 4x4mm set screw.

| < Throttle Idling > | < Throttle Hi > | < Throttle Stop > |
|--|-----------------|-------------------|
| <p>Throttle position of Tx.</p> <p>approx. 1mm</p> <p>Carburetor</p> <p>Throttle Servo</p> | | |

MOUNTING THE COWL

1. Remove the muffler and needle valve assembly from the engine. Slide the fiberglass cowl over the engine.
2. Measure and mark the locations to be cut out for engine head clearance, needle valve, muffler. Remove the cowl and make these cutouts using a rotary tool with a cutting disc and a rotary sanding drum attachment.
3. Slide the cowl back into place. Align the front of the cowl with the crankshaft of the engine. The front of the cowl should be positioned so the crankshaft is in the middle of the precut opening. Hold the cowl firmly in place using several pieces of masking tape.

4. While holding the cowl firmly in position, drill four 1,6mm pilot holes through both the cowl and the side edges of the firewall.
5. Using a 3mm drill bit, enlarge the holes in the cowling.

! *Enlarging the holes through the cowl will prevent the fiberglass from splitting when the mounting screws are installed.*

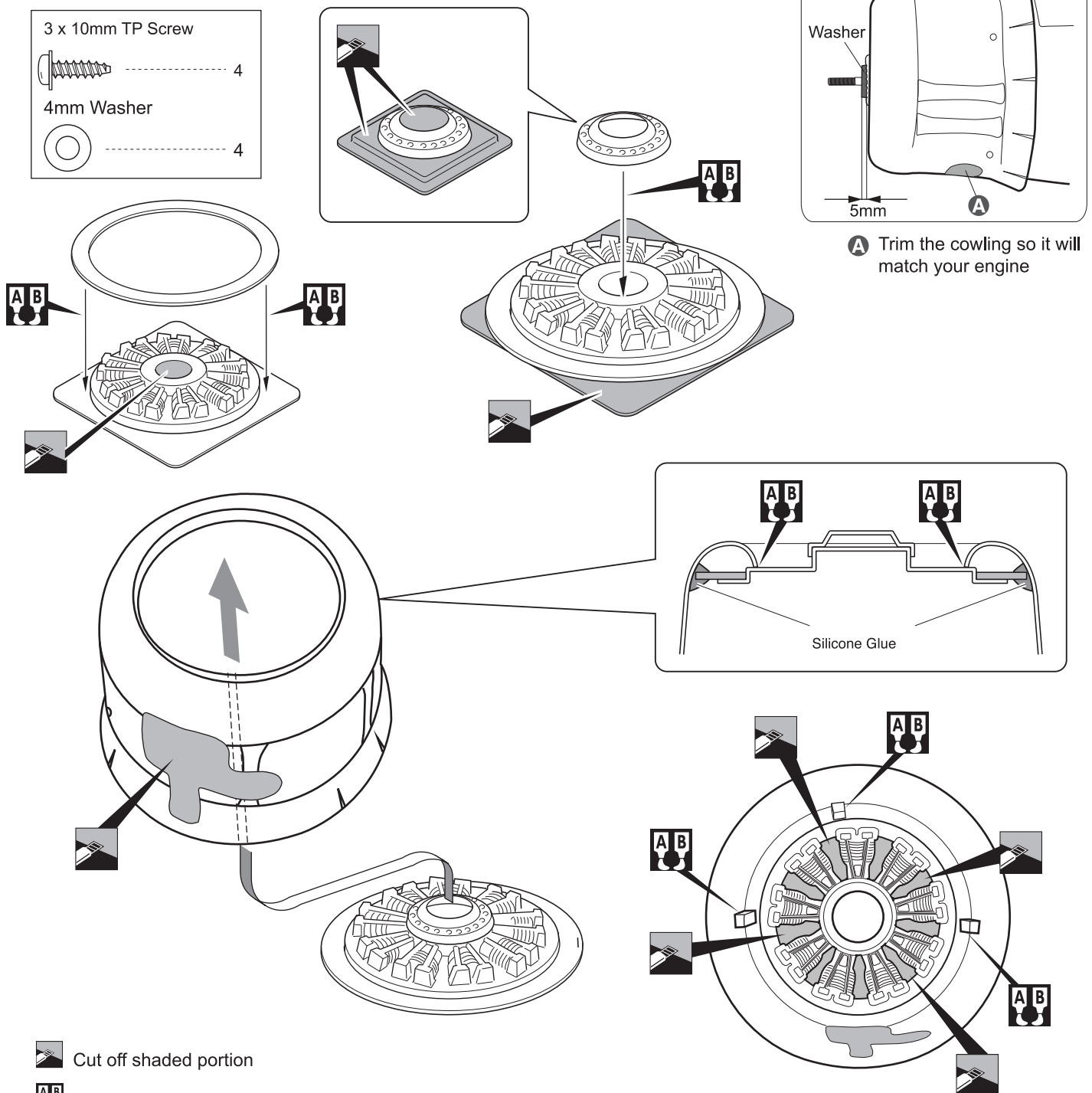
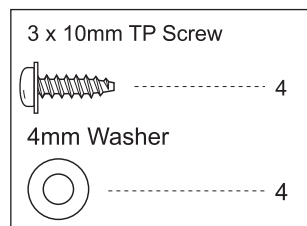

6. Slide the cowl back over the engine and secure it in place using screws.
7. Install the muffler. Connect the fuel and pressure lines to the carburetor, muffler and fuel filler valve. Tighten the screws completely.

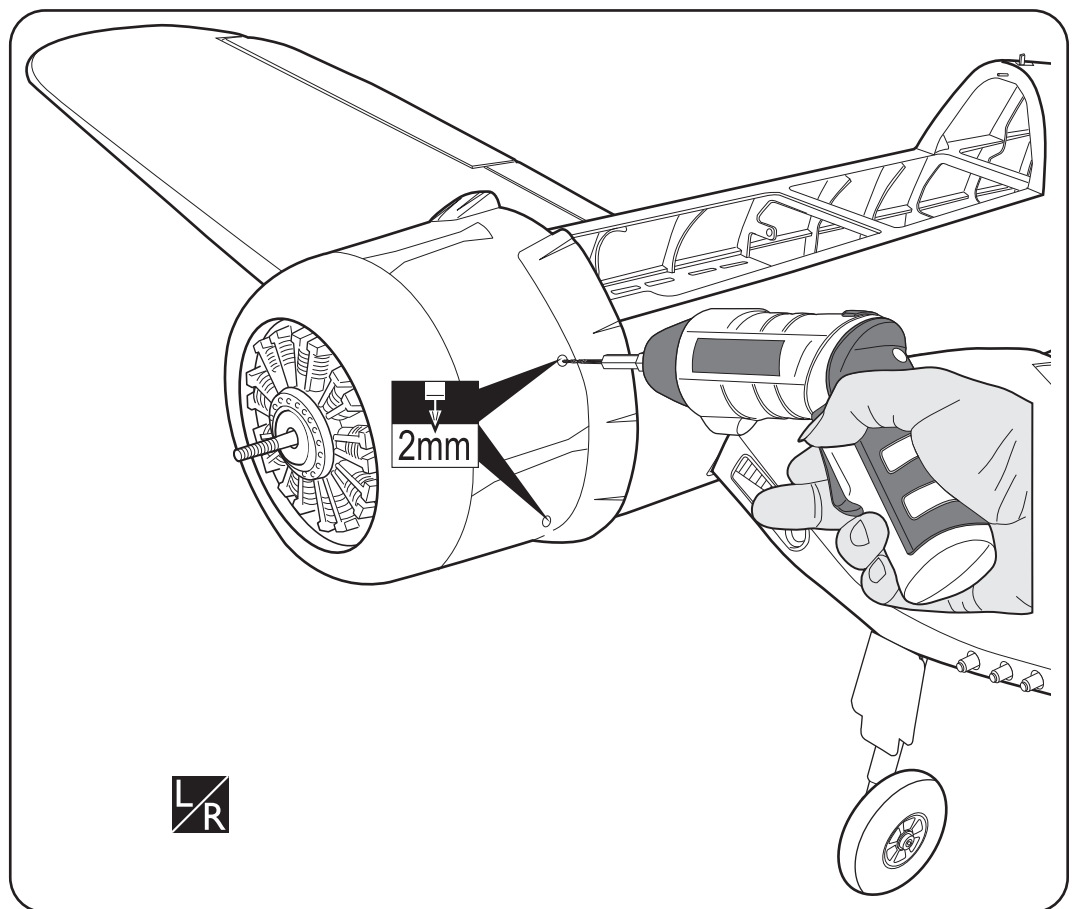
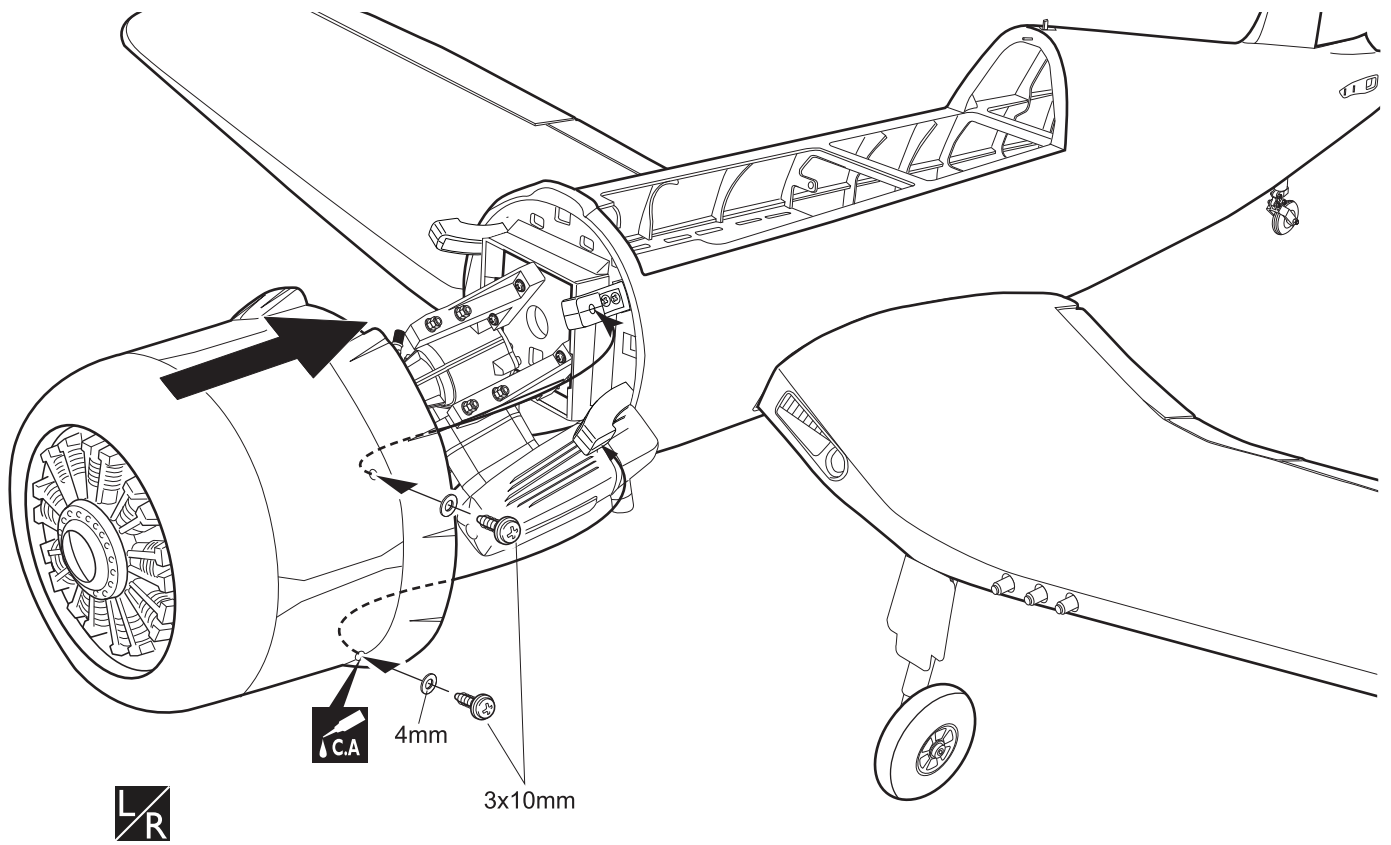

Cut off shaded portion

Apply epoxy glue



-  Apply instant glue (CA glue, super glue).
-  Assemble left and right sides the same way.
-  Drill holes with the specified diameter.

- ▶ Securely tighten the nut holding the propeller for it not come off when the motor is spinning. If coming off, there is a high risk of injury!
- ▶ Always ensure propeller and spinner are balanced. If unbalanced, vibration may result at high rotation and cause damage or injury.

INSTALLING THE PROPELLER



Warning!

- ▶ Securely tighten the nut holding the propeller for it not come off when the motor is spinning. If coming off, there is a high risk of injury!
- ▶ Always ensure propeller and spinner are balanced. If unbalanced, vibration may result at high rotation and cause damage or injury.

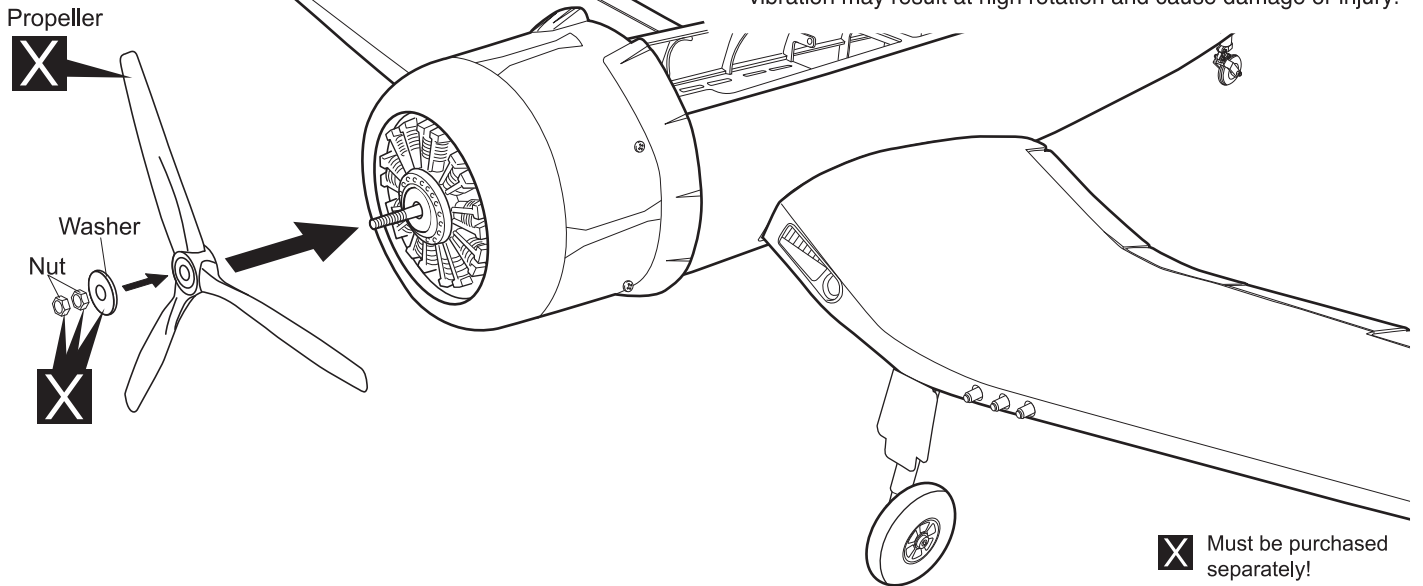

INSTALLING THE RECEIVER AND BATTERY

1. Plug the servo leads and the switch lead into the receiver. You may want to plug an aileron extension into the receiver to make plugging in the aileron servo lead easier when you are installing the wing. Plug the battery pack lead into the switch.
2. Wrap the receiver and battery pack in the protective foam to protect them from vibration. Use a rubber band or masking tape to hold the foam in place.

Do not permanently secure the receiver and battery until after balancing the model.

INSTALLING THE SWITCH

1. The switch should be mounted on the fuselage side, opposite the muffler, close enough to the receiver so the lead will reach. Use the face plate of the switch cut out and locate the mounting holes.
2. Cut out the switch hole using a modeling knife. Use a 2mm drill bit and drill out the two mounting holes through the fuselage side.
3. Secure the switch in place using the two machine screws provided with the radio system.

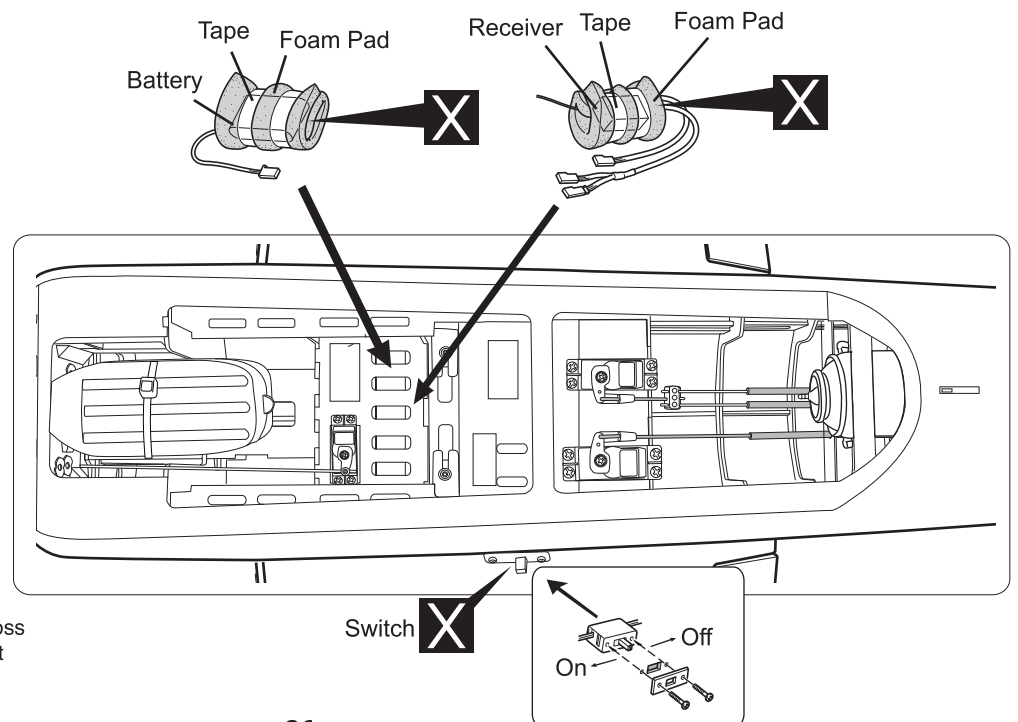



Warning!

- ▶ Attach securely. Disconnection during flight will cause loss of control and may result in an accident

Must be purchased separately!

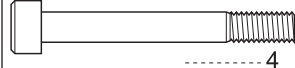
INSTALLING THE ELECTRIC MOTOR (EP VERSION)

4 x 70mm Cap Screw
 4

4 x 35mm Cap Screw
 4

4mm Washer
 8

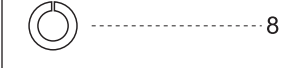
4mm Spring Washer
 8

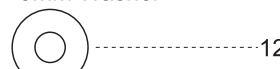

4mm Mount Nut
 4

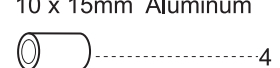
5mm Washer
 12

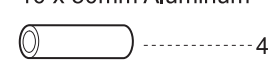
10 x 15mm Aluminum
 4

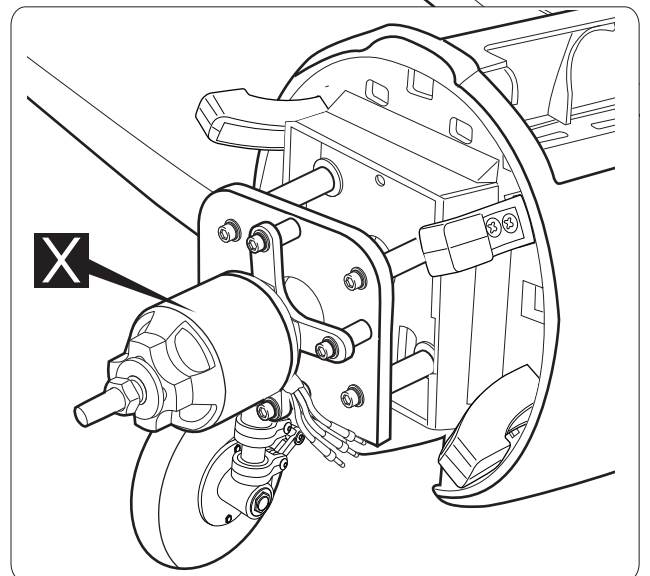
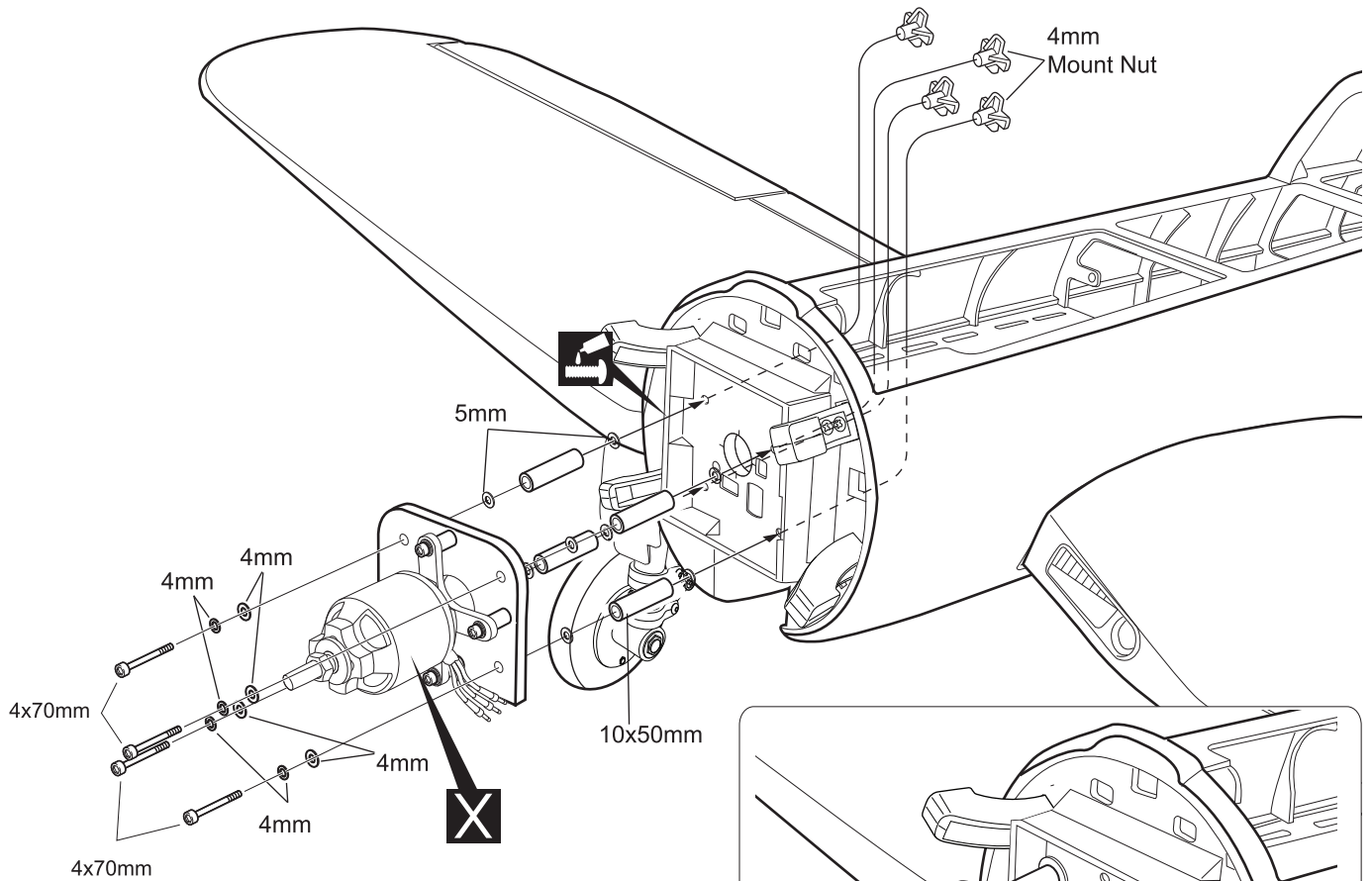
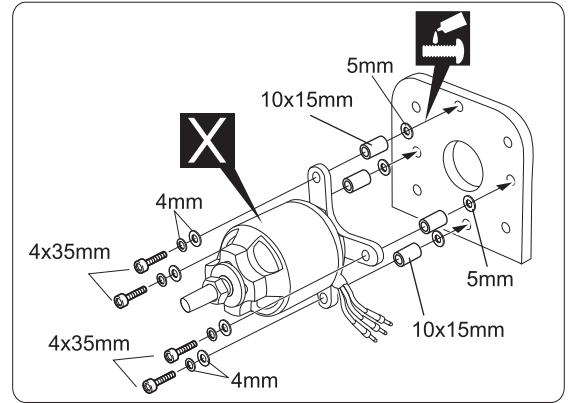
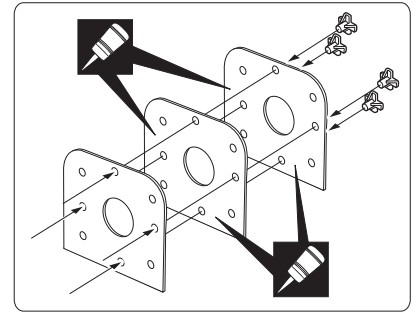
10 x 50mm Aluminum
 4



-  White glue
-  Apply threadlocker (screw cement).
-  Must be purchased separately!

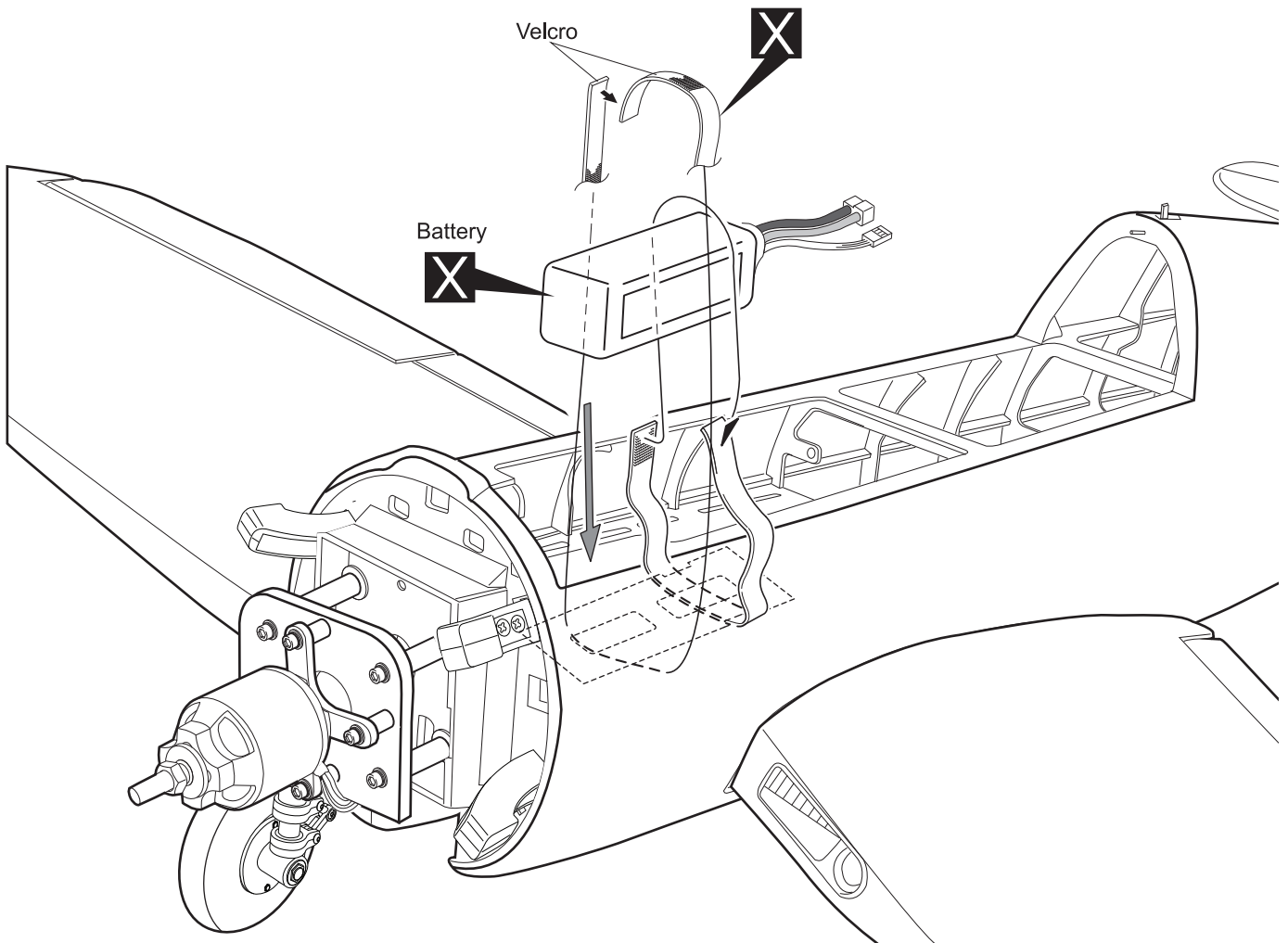
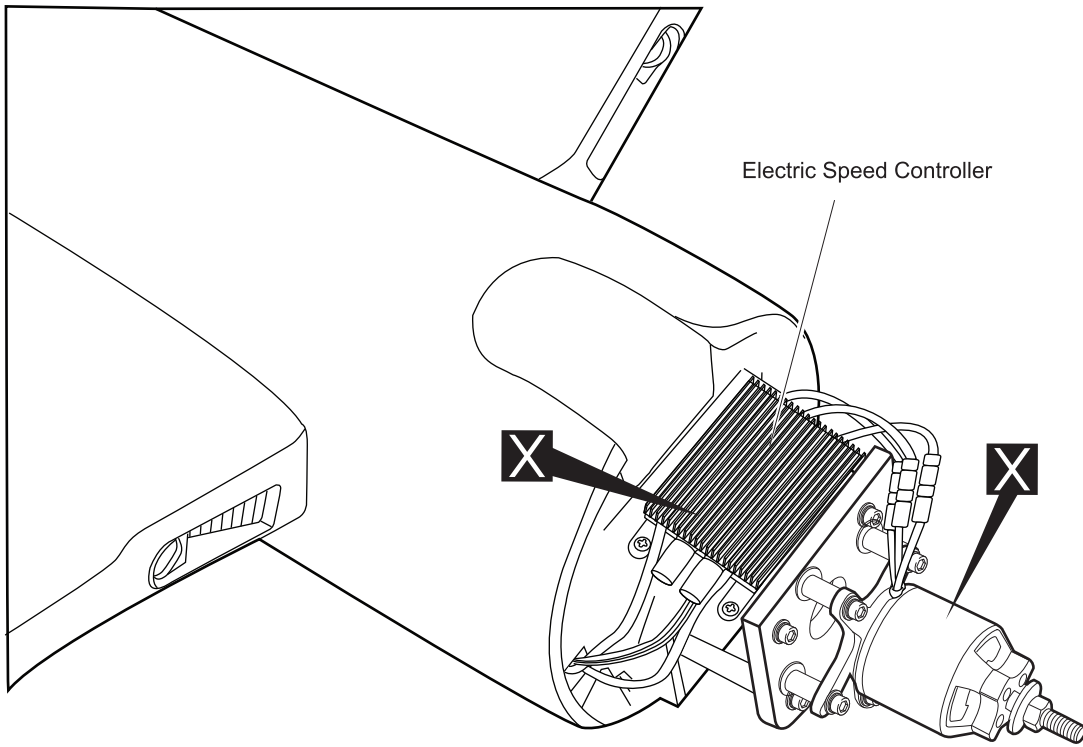

X Must be purchased separately!

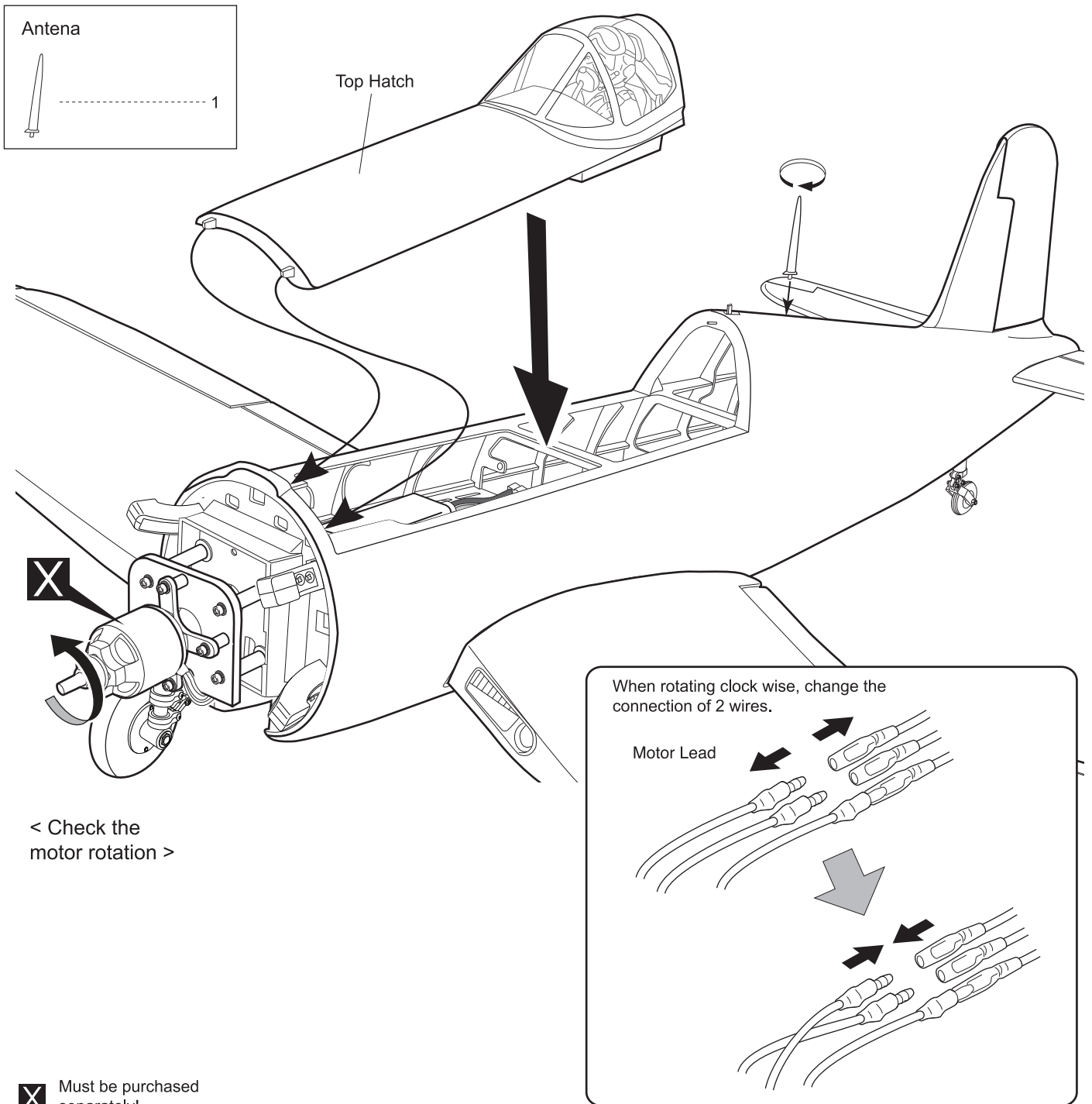

BALANCING

1. It is critical that your airplane be balanced correctly. Improper balance will cause your plane to lose control and crash.

THE CENTER OF GRAVITY IS LOCATED 115mm (4.5 in) BACK FROM THE LEADING EDGE OF THE WING, AT THE FUSELAGE. BALANCE A PLANE UPSIDE DOWN WITH THE FUEL TANK EMPTY.

2. If the nose of the plane falls, the plane is nose heavy. To correct this first move the battery pack further back in the fuselage. If this is not possible or does not correct it, stick small amounts of lead weight on the fuselage under the horizontal stabilizer. If the tail of the plane falls, the plane is tail heavy. To correct this, move the battery and receiver forward or if this is not possible, stick weight into the firewall. When balanced correctly, the airplane should sit level or slightly nose down when you lift it up with your fingers.

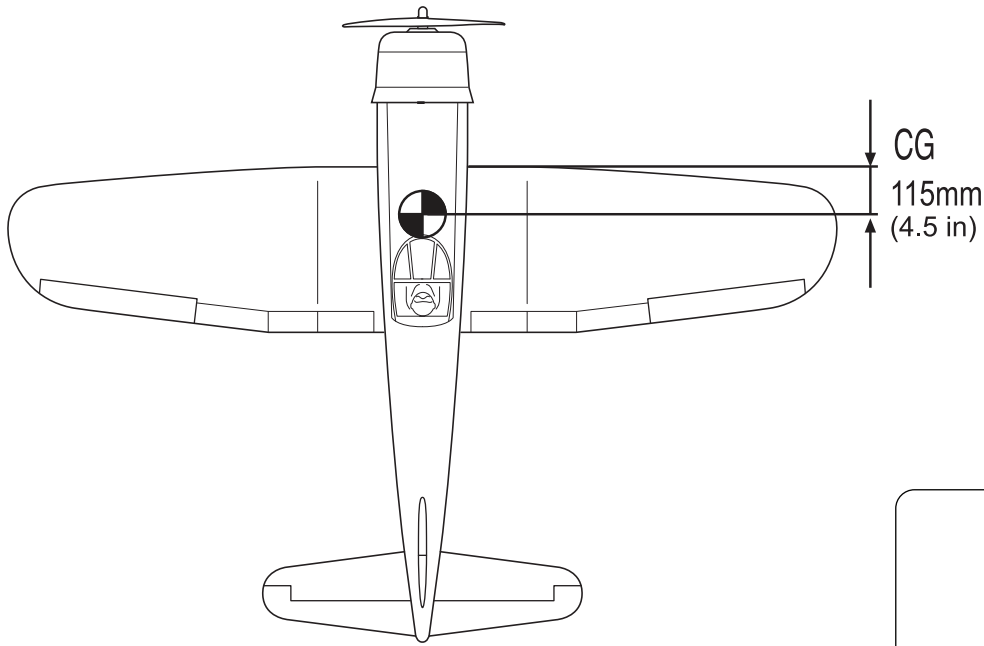

- 6mm Plastic Screw2
- 12 x 210mm Aluminum
1.5 x 1200mm1
- Plate of plywood4

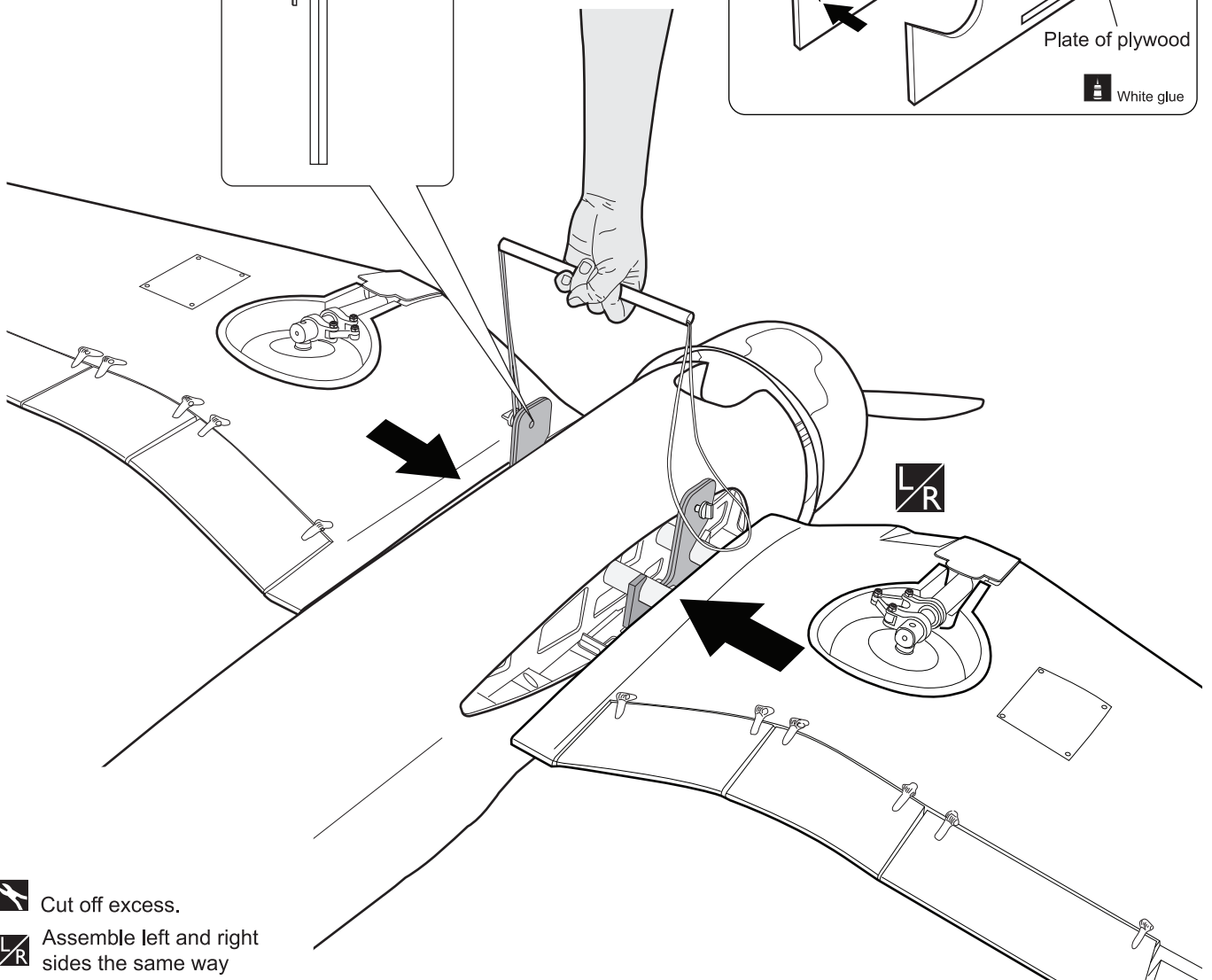
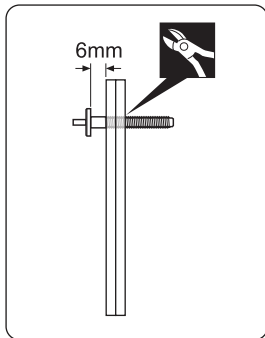
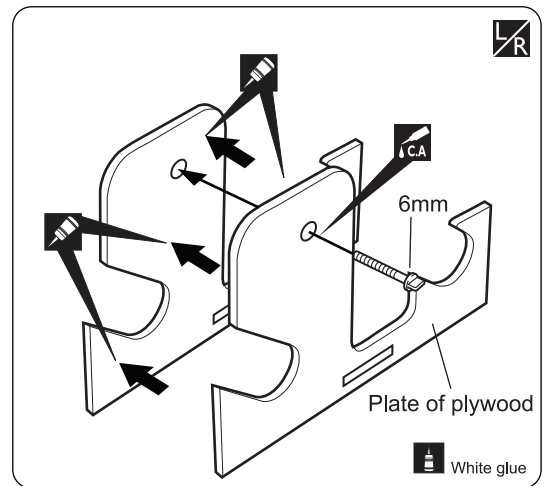

- Cut off excess.
- Assemble left and right sides the same way
- Pay close attention here
- Apply instant glue (CA glue, super glue).

- ▶ In order to obtain the CG specified, reposition the receiver and other equipment.
- ▶ If not obtain the CG specified, add a weight and adjust.



- ▶ Do not fly before confirming the correct location of the CG. If the CG is incorrect, you lose control of your airplane which leads to accidents.

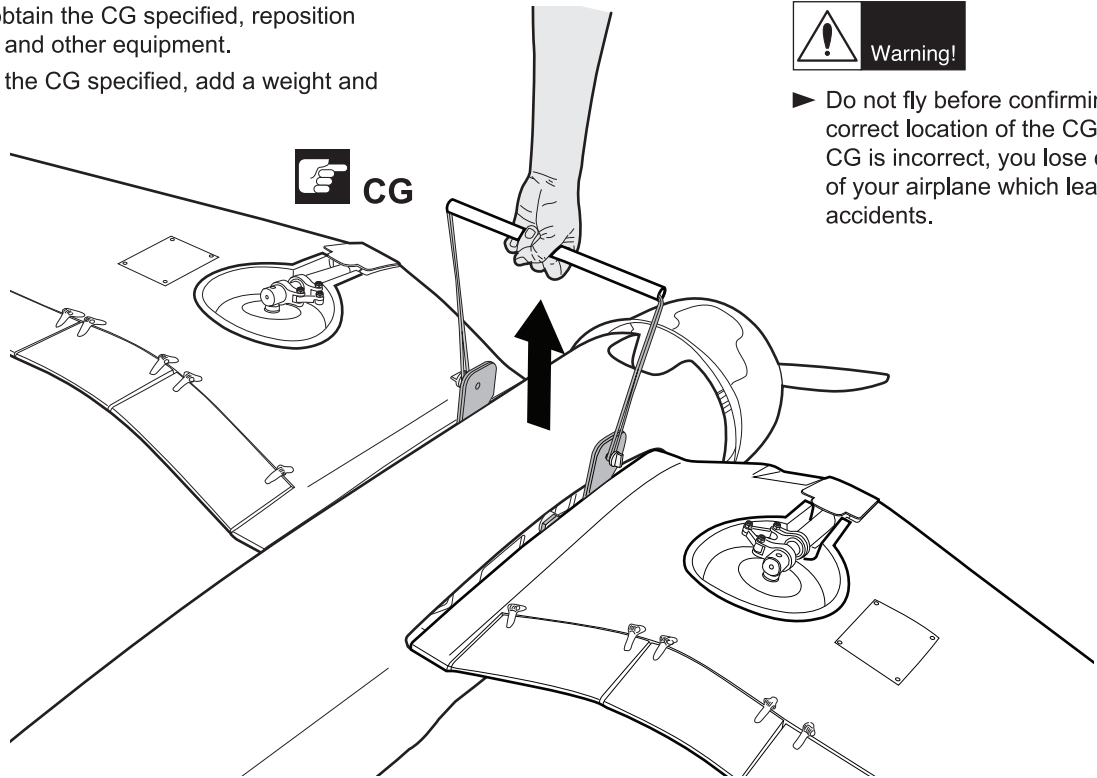

LATERAL BALANCE

! After you have balanced a plane on the C.G. You should laterally balance it. Doing this will help the airplane track straighter.

1. Turn the airplane upside down. Attach one loop of heavy string to the engine crankshaft and one to the tail wheel wire. With the wings level, carefully lift the airplane by the string. This may require two people to make it easier.
2. If one side of the wing fall, that side is heavier than the opposite. Add small amounts of lead weight to the bottom side of the lighter wing half's wing tip. Follow this procedure until the wing stays level when you lift the airplane.

● **LOW RATE**

| | | |
|----------|------------|-----------|
| Aileron | 12mm up | 12mm down |
| Elevator | 12mm up | 12mm down |
| Rudder | 15mm right | 15mm left |
| Flap | 20mm down | |

● **HIGH RATE**

| | | |
|----------|------------|-----------|
| Aileron | 15mm up | 15mm down |
| Elevator | 15mm up | 15mm down |
| Rudder | 25mm right | 25mm left |
| Flap | 30mm down | |

CONTROL THROWS

1. We highly recommend setting up a plane using the control throws listed.
2. The control throws should be measured at the widest point of each control surface.
3. Check to be sure the control surfaces move in the correct directions.

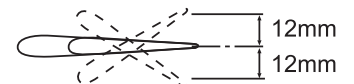
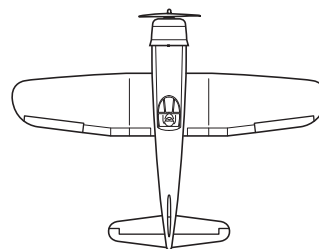

Aileron Control

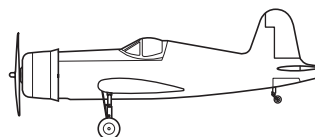

Elevator Control

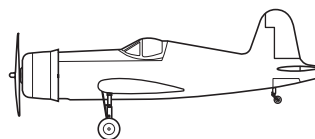

Rudder Control

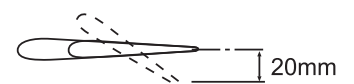
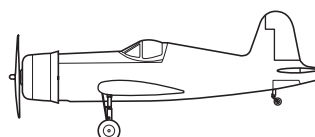

Flap Control

FLIGHT PREPARATION PRE FLIGHT CHECK

1. Completely charge your transmitter and receiver batteries before your first day of flying.
2. Check every bolt and every glue joint in your plane to ensure that everything is tight and well bonded.
3. Double check the balance of the airplane
4. Check the control surface
5. Check the receiver antenna . It should be fully extended and not coiled up inside the fuselage.
6. Properly balance the propeller.

**FOR YOUR RADIO INSTALLATION
BASIC CONNECTION FOR AIRPLANE AND ADJUSTMENT OF SERVOS**

Example of connection

- For more information, refer to radio system instruction manual.
- Follow instruction manual of Engine and Battery.

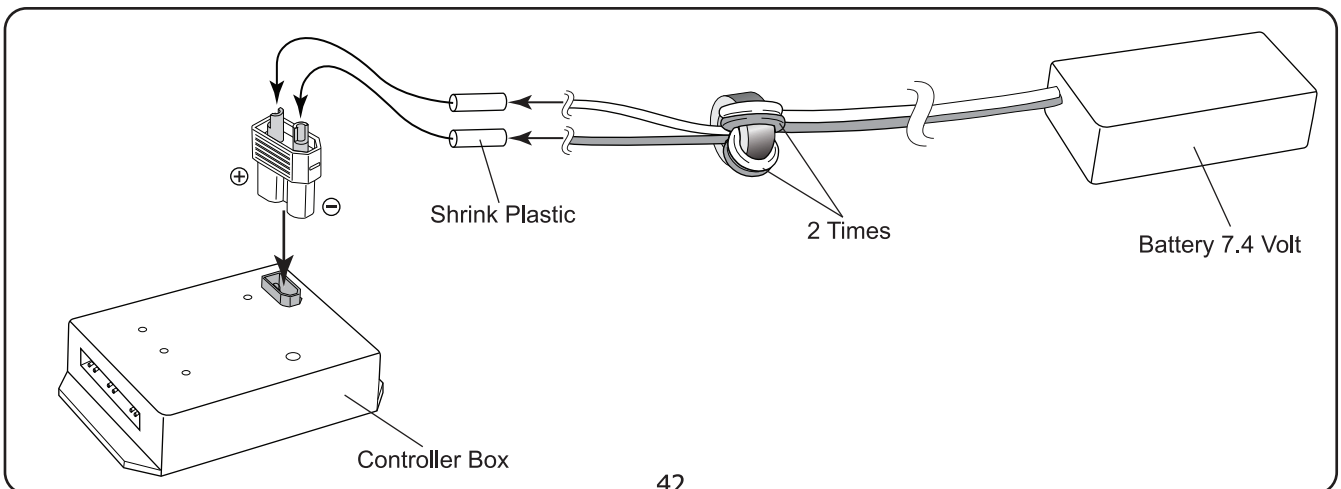
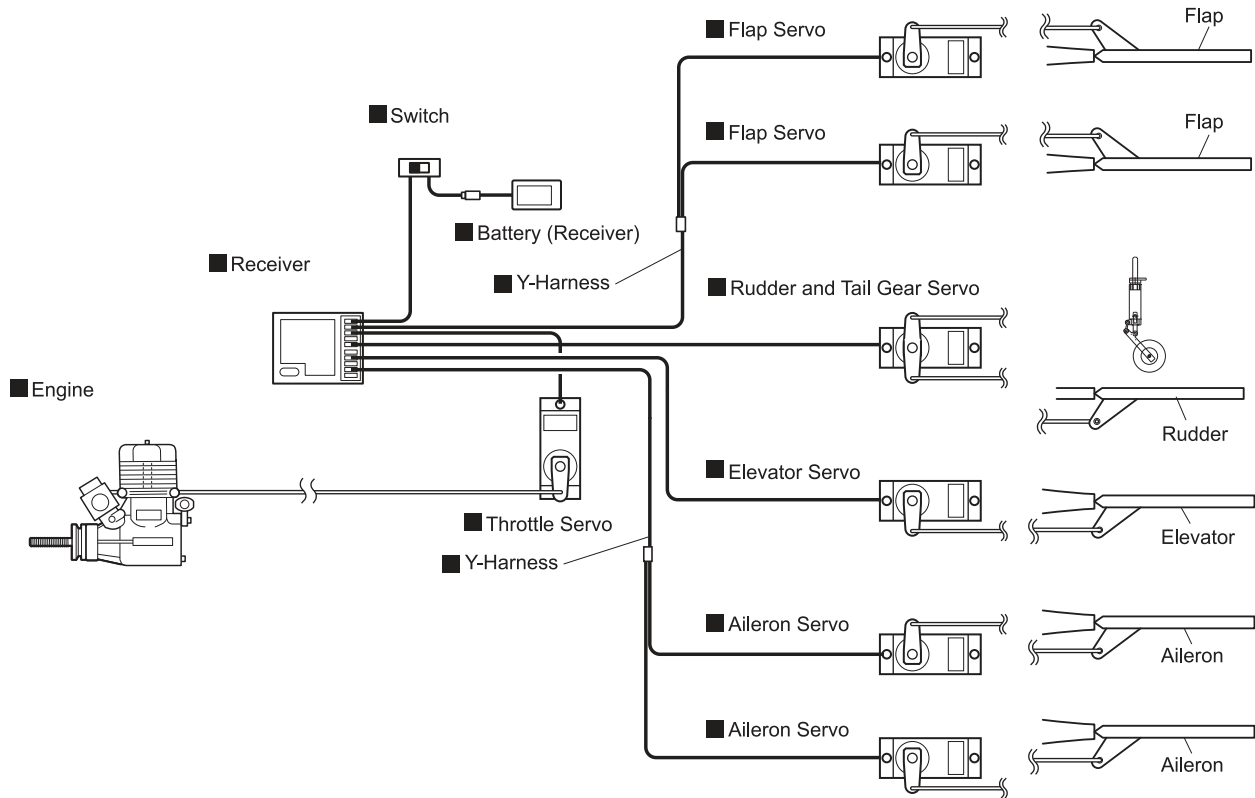

MAIN GEAR DIMENSIONAL DETAIL

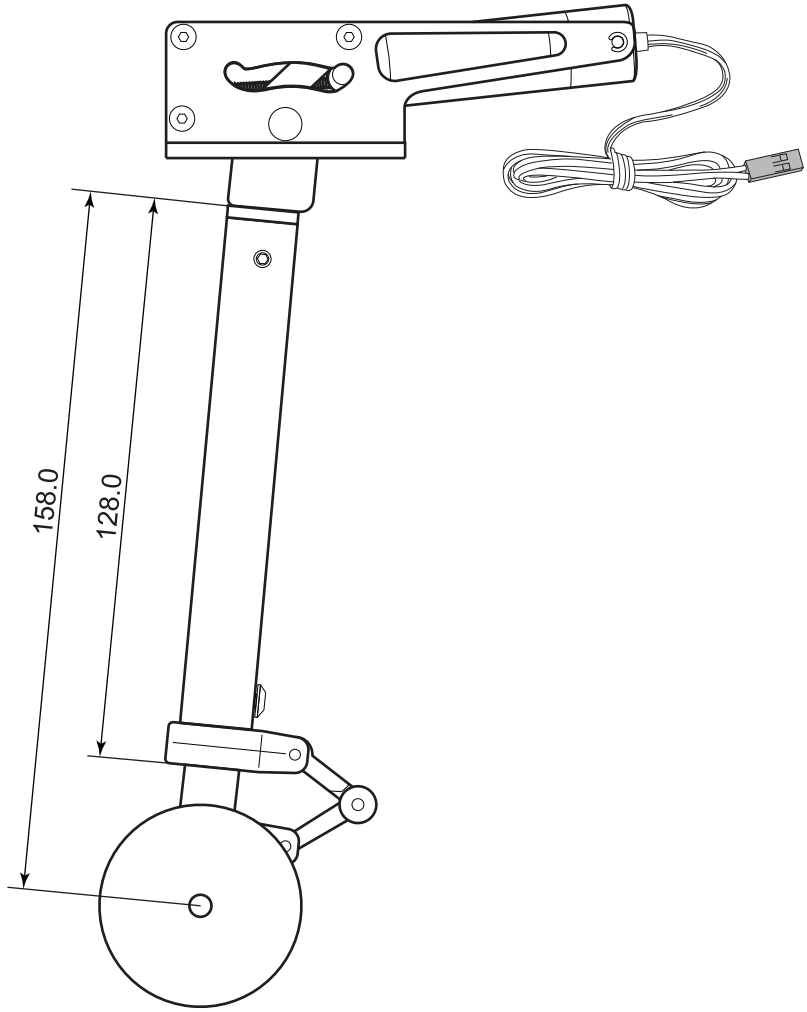

TAIL GEAR DIMENSIONAL DETAIL

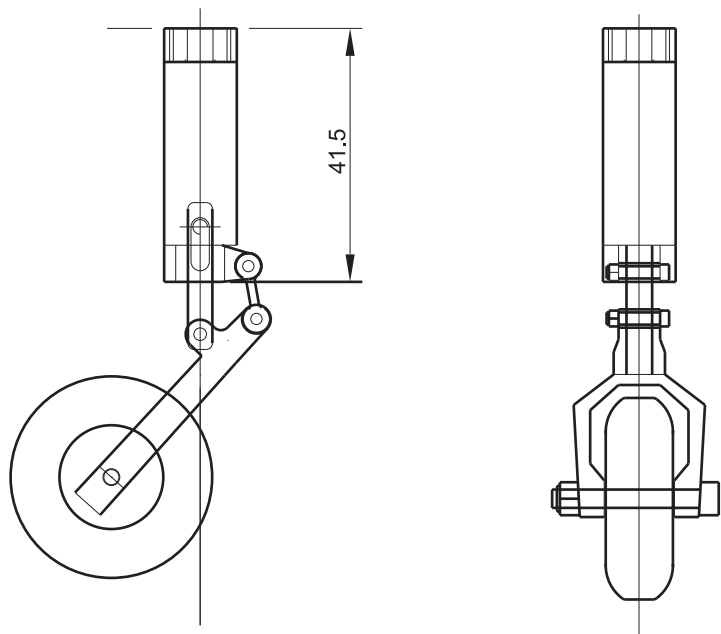

DECORATION

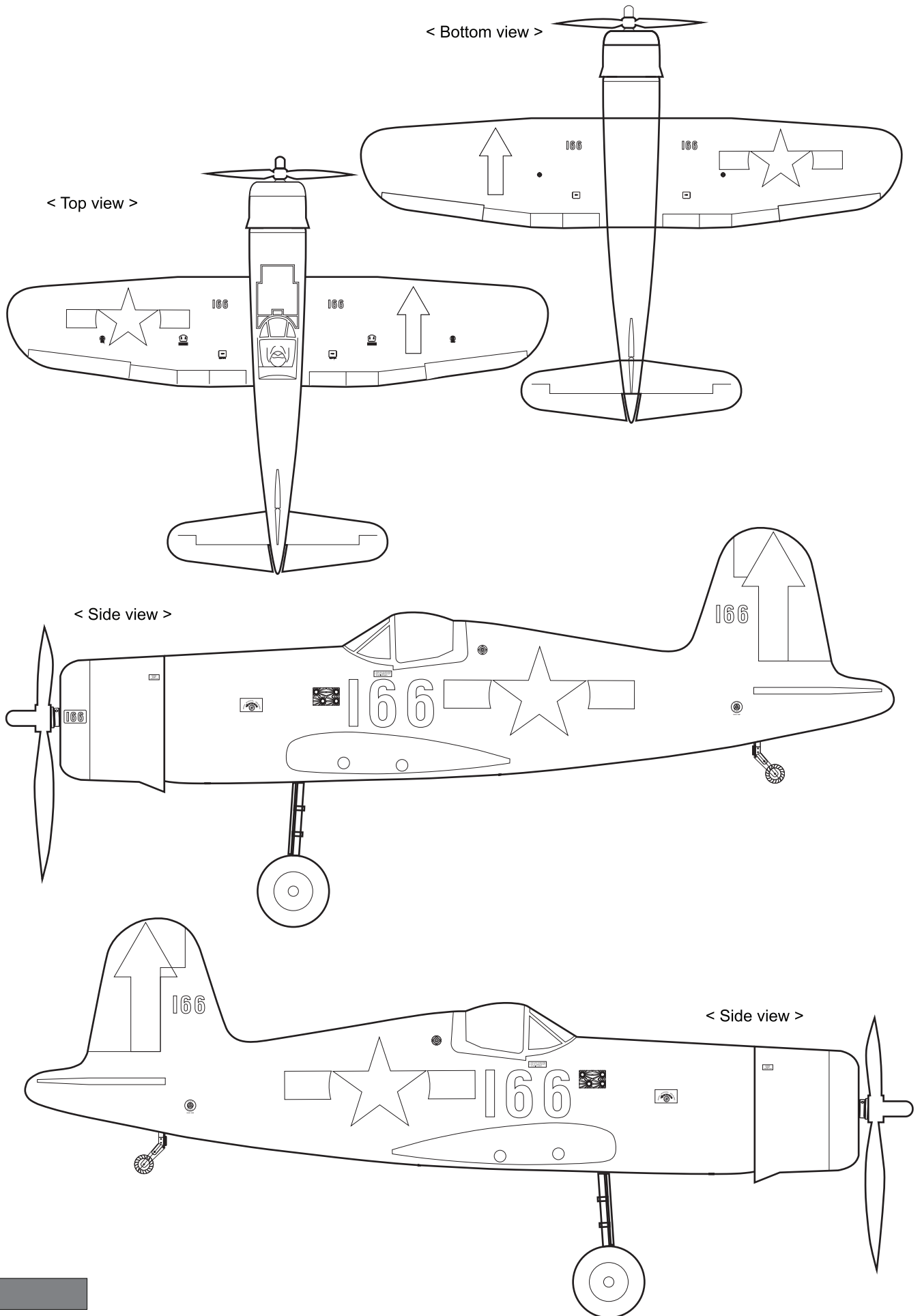

#019 - Corsair Blue

EXPLODED VIEW

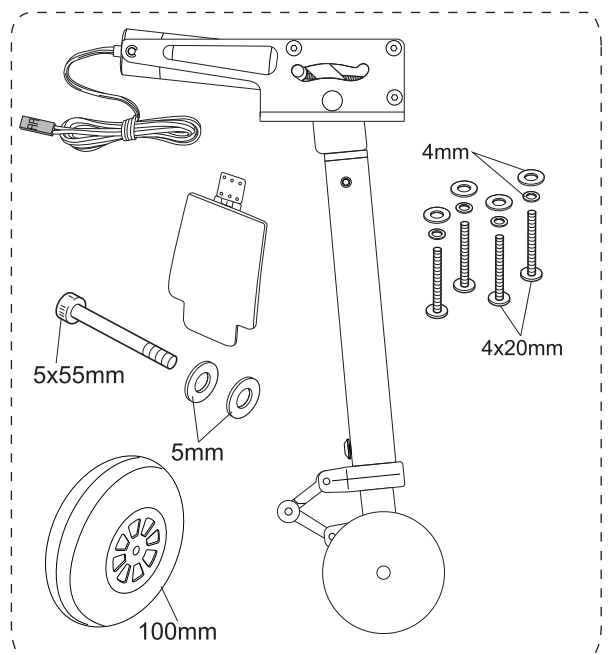
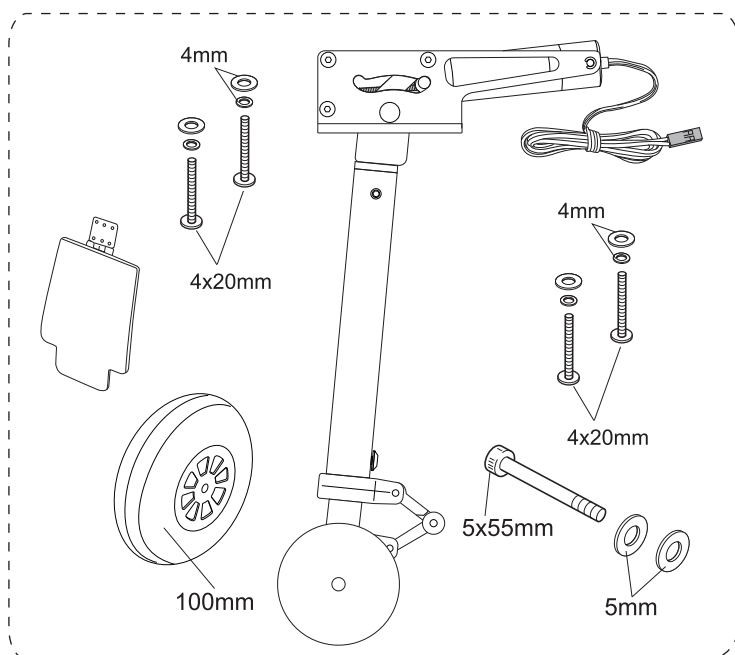
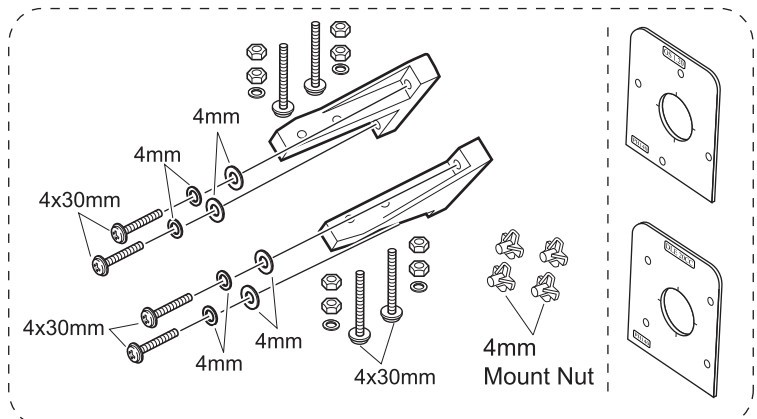
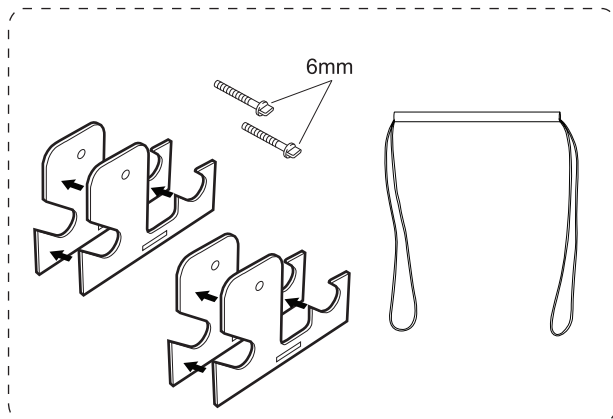
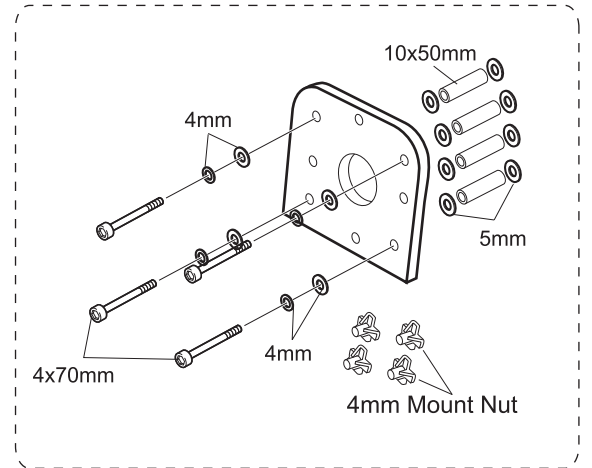
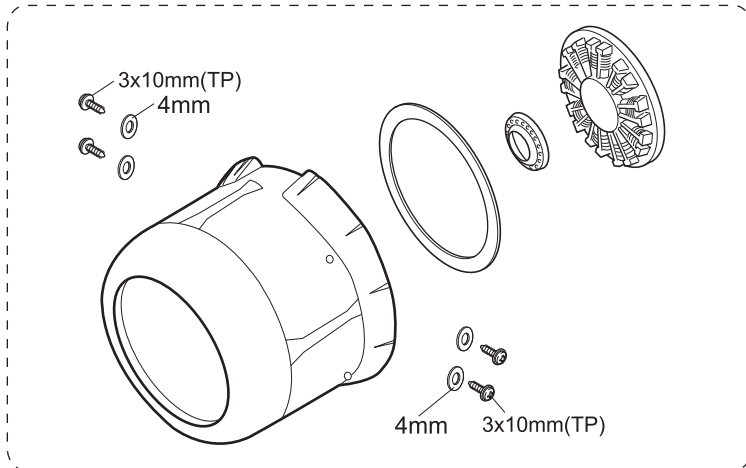
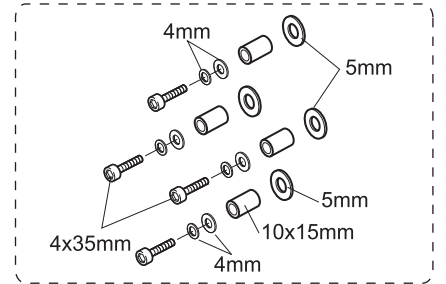
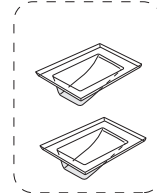
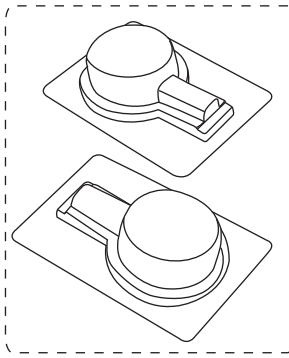
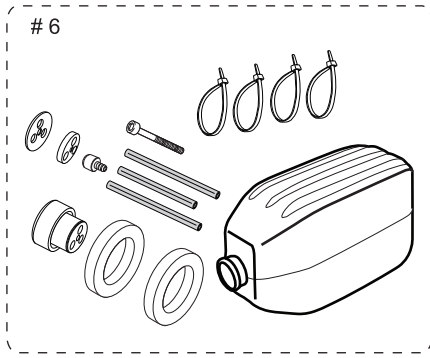

EXPLODED VIEW

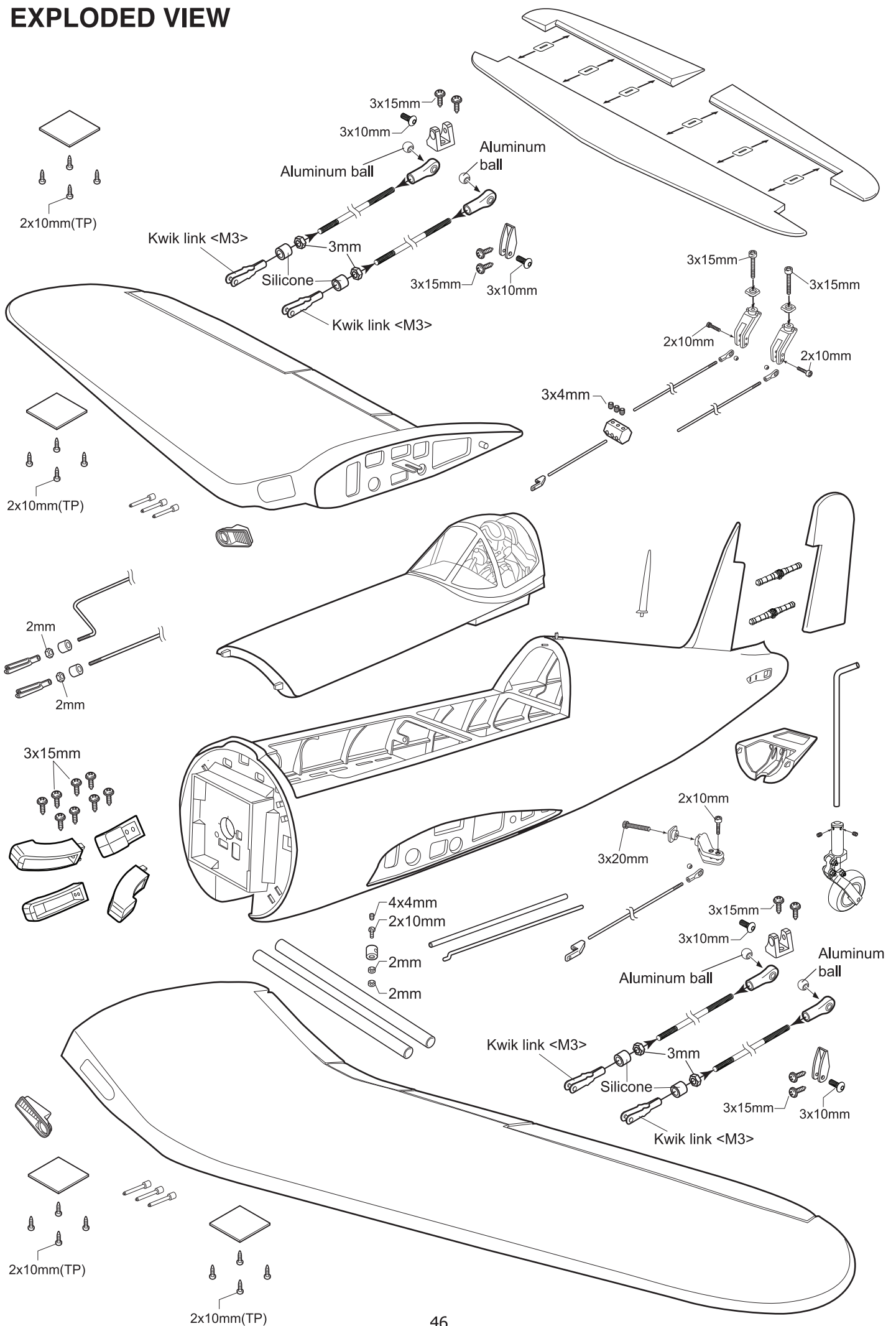

I/C FLIGHT GUIDELINES

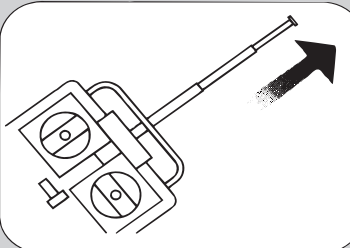

When ready to fly, first extend the transmitter aerial.

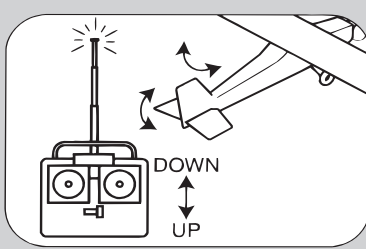

Operate the control sticks on the transmitter and check that the control surfaces move freely and in the CORRECT directions.

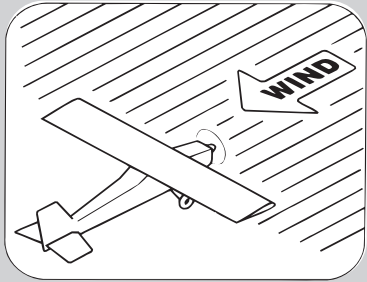

ALWAYS land the model INTO the wind, this ensures that the model lands at the slowest possible speed.

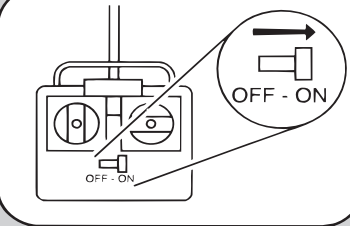

Switch on the transmitter.

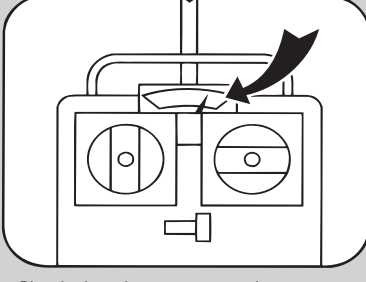

Check that the transmitter batteries have adequate power.

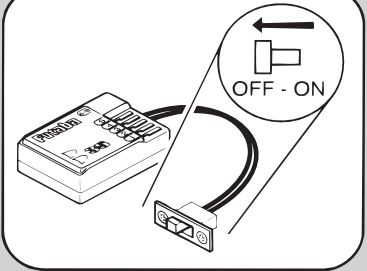

Switch off the receiver.

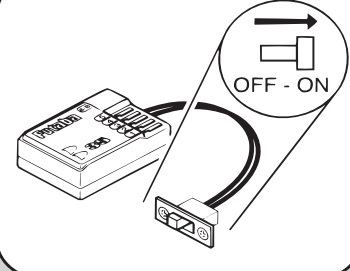

Switch on the receiver.



ALWAYS take off into the wind.

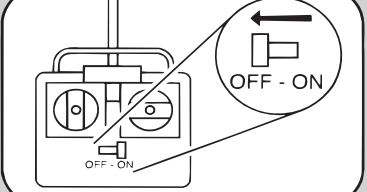

Switch off the transmitter.

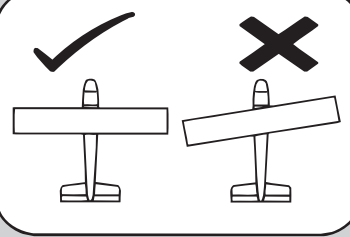

Check that the wings are correctly fitted to the fuselage.

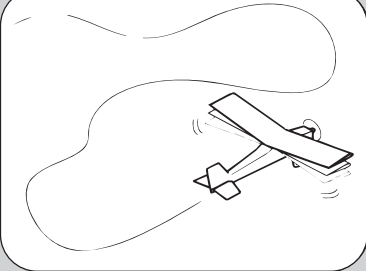

If the model does not respond correctly to the controls, land it as soon as possible and correct the fault.

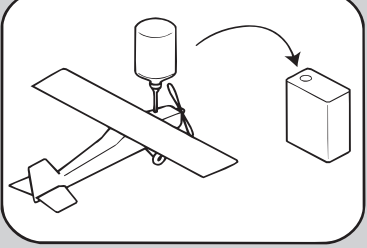

Empty the fuel tank after flying, fuel left in the tank can cause corrosion and lead to engine problems.